



## Basic SBD Information

Stock, Super Stock and Masters Divisions

The information in this document is opinion based upon years of SBD experience, my understanding of the physics involved, currently approved SBD parts, and current (2007/2008) SBD rules.

The specific features, conditions and setups that make a SBD car go fast change with track, ramp, part and rule changes. The science does not change, but the application of the science changes based upon different tracks, ramps, parts, and rules.

### **Primary Influences on a SBD Car** *(Listed in random order)*

- (a) Potential Energy (PE) *[Gravitational Potential Energy for Soap Box Derby cars]*
- (b) Acceleration
- (c) Kinetic Energy (KE)
- (d) Aerodynamics
- (e) Center of Mass (CM) *[also known as Center of Gravity]*
- (f) Balance
- (g) Moment of Inertia
- (h) Vibration
- (i) Friction
- (j) Driver

The primary influences change order of importance based upon the track, ramp, and lane driving requirements of a specific race.

### **Goals** *(Listed in same order as Primary Influences)*

- (a) Maximum Potential Energy
- (b) Maximum acceleration
- (c) Most efficient conversion from Potential Energy to Kinetic Energy
- (d) Minimum aerodynamic drag
- (e) Lowest possible Center of Mass
- (f) Correct balance for track and ramp combination
- (g) Minimum Moment of Inertia
- (h) Minimum vibration of car and parts in car
- (i) Minimum friction
- (j) Minimum driving

The car and driver best at achieving the goals stated above will win.

It is important to understand the different influences that act upon a car when selecting parts, assembling the car, and racing but, only testing on a specific track with a specific car and driver will determine what works best on that track with that car and driver.

Read everything, listen to everyone, observe what others are doing, test, and then use your own judgment to determine what will make your car go fast.

Paul Gale

## Basic SBD Information

Stock, Super Stock and Masters Divisions

### Notes / Disclaimers

1. The focus of this document is on the primary influences, conditions and setups that impact the speed of a SBD car.
2. Estimates are not provided for the increase or decrease in speed that may result from the conditions and setups mentioned in this document. Individual contestant ability to achieve the goals and the specific race conditions would change any estimate provided.
3. There will be exceptions to all statements and recommendations in this document due to specific and unique part, track and ramp conditions. Possible exceptions and their impact are not addressed in this document.
4. Selecting the best parts and determining the best car setup for racing involves trade-offs. The difficulty for contestants is working out the trade-offs to make their car as fast as possible on a specific track and ramp combination. Two examples of trade-offs:
  - a. On a constant slope hill with a flat ramp (same slope as track), distributing weight to create a tail heavy car increases Potential Energy, but also increases rear wheels friction. The increased wheel friction may slow the car down more than the additional Potential Energy speeds it up.
  - b. On a varying slope hill with a flat ramp (same slope as track), locating weight near the axles creates the lowest possible Center of Mass increasing Potential Energy, but also increases the car's Moment of Inertia. Depending upon the specific hill slope and length, the increased Moment of Inertia may slow the car down more than the additional Potential Energy speeds it up.
5. It is not suggested or recommended that official SBD parts be altered or modified to achieve the optimum conditions shown in this document.

# Basic SBD Information

Stock, Super Stock and Masters Divisions

## Index

	Page
<b>Primary Influences</b>	5
(a) Potential Energy	6
(b) Acceleration	7
(c) Kinetic Energy	8
(d) Aerodynamics	9
(e) Center of Mass	10
(f) Balance	11
(g) Moment of Inertia	12
(h) Vibration	13
(i) Friction	15
(j) Driver	16
<b>Floorboard Conditions</b>	18
1. Twisted or Wrapped	19
2. Cupped	19
3. Bowed	20
4. Width	21
5. Thickness	21
6. Rear King Pin Bushing Hole Mislocated Along Center Line	22
7. Front King Pin Bushing Hole Mislocated Along Center Line	22
8. One King Pin Bushing Hole Mislocated Off Center Line	23
9. Both King Pin Bushing Holes Mislocated Off Center Line	23
10. King Pin Hole(s) Not Drilled At 90 Degrees	24
11. King Pin Bushing Hole(s) Oversize	24
Ideal Floorboard #1 – No Bow and Cup Defects	25
Ideal Floorboard #2 – Bow and Cup Defects Used to Advantage	26
Floorboard Condition Data Sheet	27
<b>Axles Conditions</b>	30
1. Square Stock	31
2. Spindles	34
3. King Pin Hole	36
4. Ideal Axle	39
<b>Weight Distribution</b>	41
1. Track and Ramp Types	41
2. General Information	42
3. Potential Energy on Ramp	43
4. Potential Energy on Track	44
5. Basic Weight Distribution Recommendations	45
<b>Car Assembly</b> (future addition)	---
<b>Racing</b> (future addition)	---
<b>Miscellaneous Information</b>	49
1. Time into Inches Conversion Data	50
2. Increased Track Length Due to Steering	51
3. Balanced Verse Ramp Angle (future addition)	---

**Basic SBD Information**  
Stock, Super Stock and Masters Divisions

**Index – Primary Influences**

	Page
<b>Primary Influences</b> .....	5
(a) Potential Energy.....	6
(b) Acceleration.....	7
(c) Kinetic Energy.....	8
(d) Aerodynamics.....	9
(e) Center of Mass.....	10
(f) Balance.....	11
(g) Moment of Inertia	
a. Car.....	12
b. On Track.....	13
(h) Vibration.....	14
(i) Friction.....	15
(j) Driver.....	16

## **Basic SBD Information**

Stock, Super Stock and Masters Divisions

### **Primary Influences**

The force that propels a SBD car and driver down the track is gravity. The amount of force available, called Potential Energy, is determined by total weight of car and the vertical drop of that weight from start to finish.

When the starting gate releases a car, it accelerates down the hill. While accelerating, the car's Potential Energy (PE) is converted into Kinetic Energy (KE). The more efficiently PE is converted to KE, the faster the car goes.

A car's acceleration is impeded as it rolls down the hill by aerodynamic drag, vibration, friction, Moment of Inertia, and most important: driving. Minimizing the impact of these primary influences will increase the car's speed.

The following pages provide a definition for each of the Primary Influences.

# Basic SBD Information

Stock, Super Stock and Masters Divisions

## Definition of Primary Influence

**(a) Potential Energy:** Energy of an object due to its position. *[on ramp, not moving]*

*Gravitational Potential Energy*

Maximum Potential Energy occurs on ramp before starting gate is released.

No Kinetic Energy on ramp.

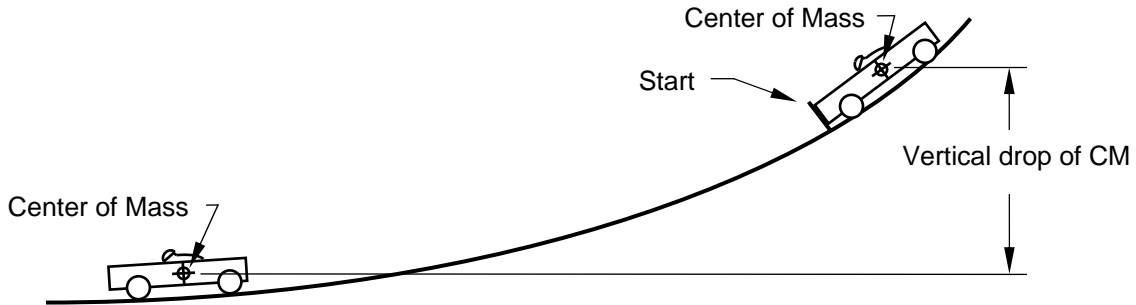

No Potential Energy remains when car reaches maximum speed.

**To calculate Potential Energy (PE):** Multiply total weight of car and driver times the car's Center of Mass vertical drop.

*(The vertical drop at Akron is approximately 45 feet).*

1 pound x 45 feet = 45 foot pounds of Potential Energy

2 lbs. x 45 ft. = 90 ft. lbs. of PE

5 lbs. x 45 ft. = 225 ft. lbs. of PE

200 lbs. x 45 ft. = 9,000 ft. lbs. of PE *(Stock)*

230 lbs. x 45 ft. = 10,350 ft. lbs. of PE *(Super Stock)*

255 lbs. x 45 ft. = 11,475 ft. lbs. of PE *(Masters)*

260 lbs. x 45 ft. = 11,700 ft. lbs. of PE

**Figure 1**

## Basic SBD Information

Stock, Super Stock and Masters Divisions

### Definition of Primary Influence

**(b) Acceleration:** The rate of change of an object's speed.

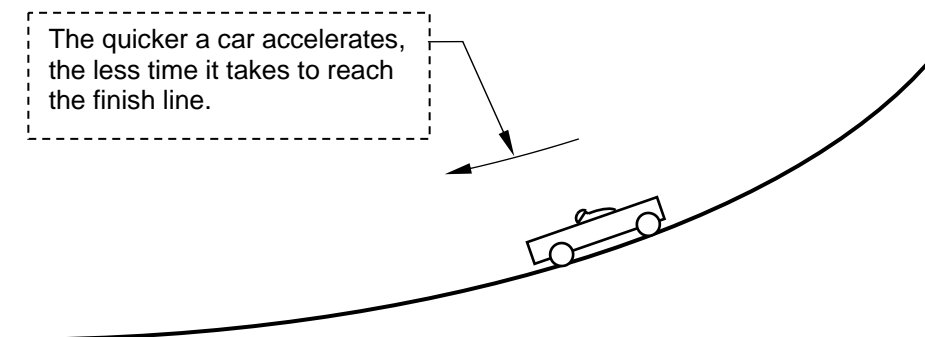

#### Acceleration is impeded by:

1. Debris on wheel tread (such as small rocks)
2. "Flat" spot on wheel tread due to sitting in starting gate for a long period of time.
3. Imperfections in ramp surface
4. Wheel bearing breakaway torque
5. Wheel tread "squirm" rolling down hill
6. Rough track surface
7. Aerodynamic drag
8. Friction
9. Vibration
10. Moment of Inertia
11. Steering of car by driver

**Figure 2**

## Basic SBD Information

Stock, Super Stock and Masters Divisions

### Definition of Primary Influence

**(c) Kinetic Energy:** Energy of an object due to its motion. *[rolling down hill]*

Potential Energy is converted into Kinetic Energy as the car rolls down hill.

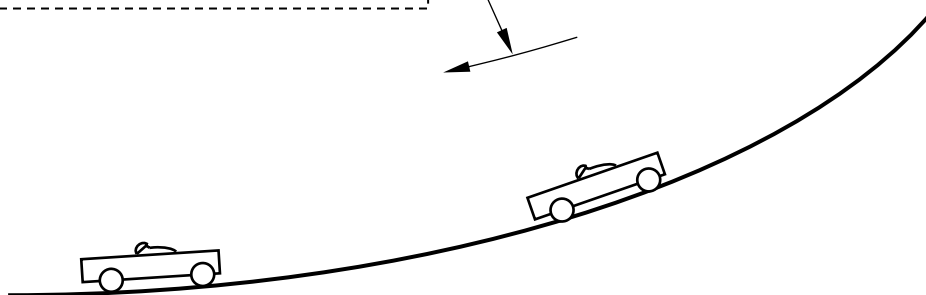

Maximum Kinetic Energy (maximum force) occurs at maximum speed.

No Potential Energy remains.

**Figure 3**

# Basic SBD Information

Stock, Super Stock and Masters Divisions

## Definition of Primary Influence

**(d) Aerodynamics:** Effects produced by air upon an object.

### Examples of aerodynamic drag (*air resistance*):

- 1) Driver position (impacts cross section area)
- 2) Large car body size
- 3) Airfoils misaligned
- 4) Surface roughness

#### 1) Driver Position

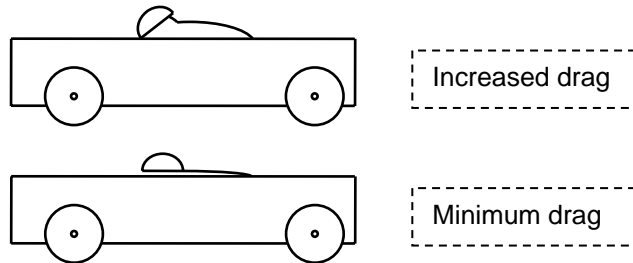

#### 2) Car Body

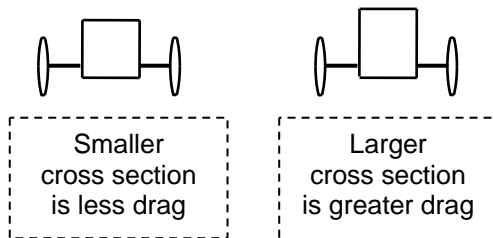

#### 3) Airfoils

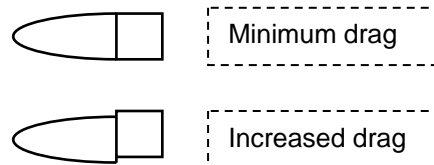

#### 4) Surface Roughness

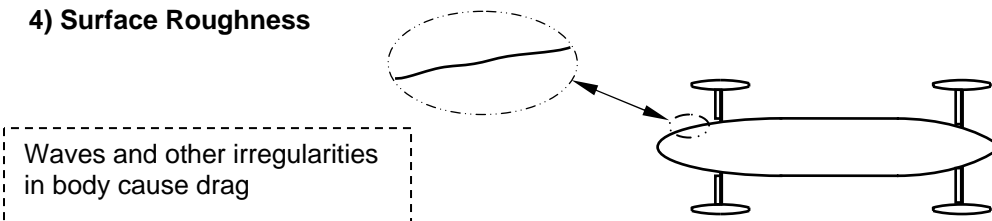

Figure 4

# Basic SBD Information

Stock, Super Stock and Masters Divisions

## Definition of Primary Influence

**(e) Center of Mass:** Point at which weight of object is centered. *[all three axis]*

The weight of all car parts, added weight and driver in racing position are combined to determine Center of Mass.

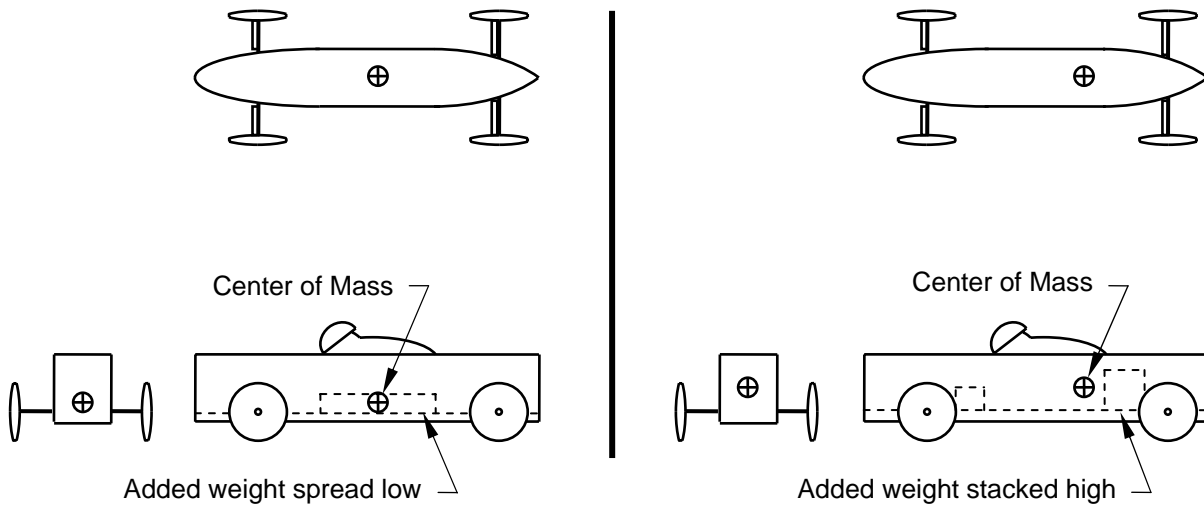

### Low

1. Spreading out weight lowers Center of Mass.

### High

1. Stacking weight raises Center of Mass

Figure 5

## Basic SBD Information

Stock, Super Stock and Masters Divisions

### Definition of Primary Influence

(f) **Balance:** Weight of car and driver measured at axles.

Balance is determined when car and driver are at total weight and the driver is in driving position.

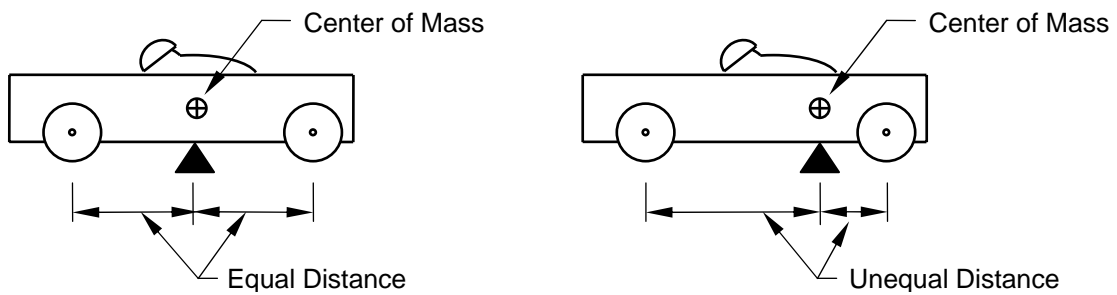

#### **Balanced** (Equal Weight)

1. Equal weight on front and rear axles.
2. Equal weight on each of the four wheels.

#### **Tail Heavy** (Unequal weight)

1. Rear axle weight heavier than front axle.

**Figure 6**

## Basic SBD Information

Stock, Super Stock and Masters Divisions

### Definition of Primary Influence

#### (g) Moment of Inertia

**a. Car:** An object's resistance to rotating about its Center of Mass (CM).

*In illustrations below, the car is shown in a theoretical "Free State" (no constraints). It is not rolling down a hill. The car and driver are shown rotating about the car's Center of Mass.*

*Each wheel, part, and the driver in position has its own Moment of Inertia. The "car's" Moment of Inertia is determined by the sum of all wheels, parts, and driver in position.*

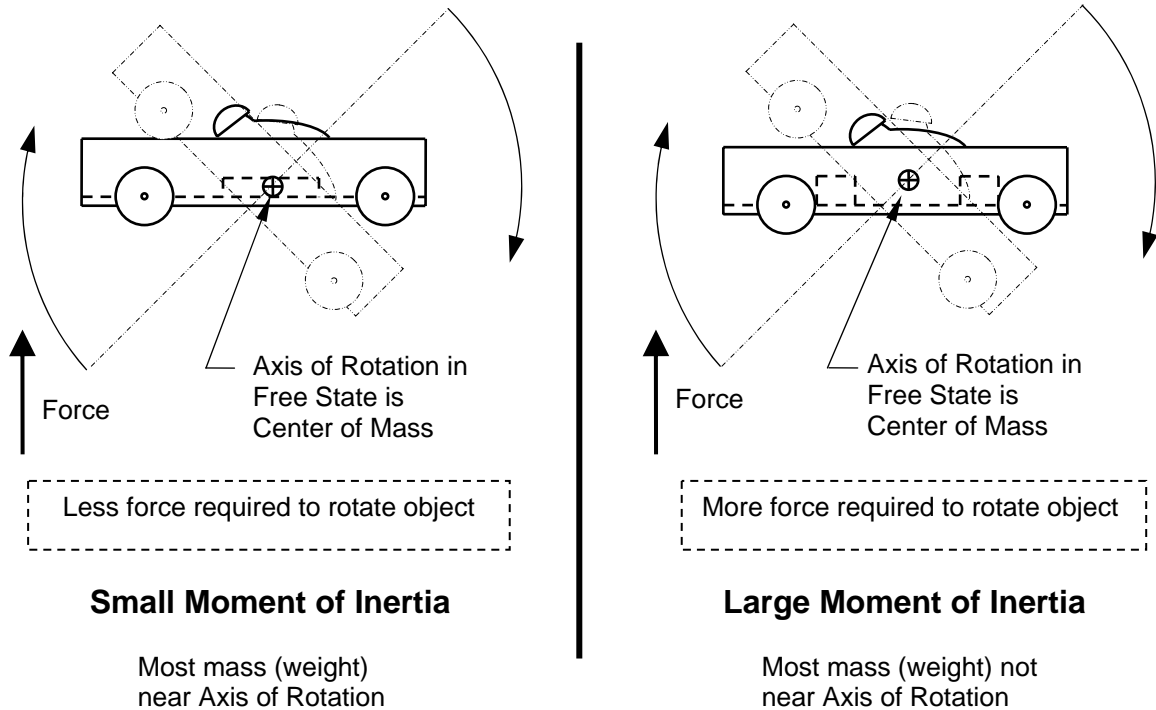

1. All weight (car body, wheels, axles, added weight, driver, etc.) not located at the Center of Mass increases the car's Moment of Inertia.
2. The farther a weight is from the CM, the larger the Moment of Inertia.
3. Following current rules (2007/2008), only driver position and weight added to the car can be adjusted to minimize car's Moment of Inertia.

**Figure 7**

# Basic SBD Information

Stock, Super Stock and Masters Divisions

## Definition of Primary Influence

### (g) Moment of Inertia

**b. On Track:** An object's resistance to angular acceleration.

The most common type of track/street used for SBD racing is a varying slope (Concave slope). The slope at the start is greater than the slope at the finish. The car rotates while rolling down the hill due to the varying slope. This rotation causes loss of energy due to the car's Moment of Inertia. Reducing the car's Moment of Inertia will reduce the energy loss.

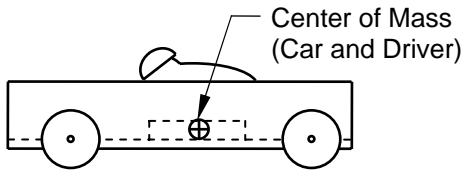

#### Example 1:

Car with small Moment of Inertia due to location of added weight in center of car

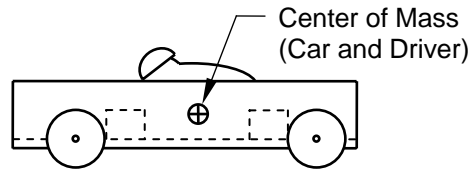

#### Example 2:

Car with large Moment of Inertia due to location of added weight near axles

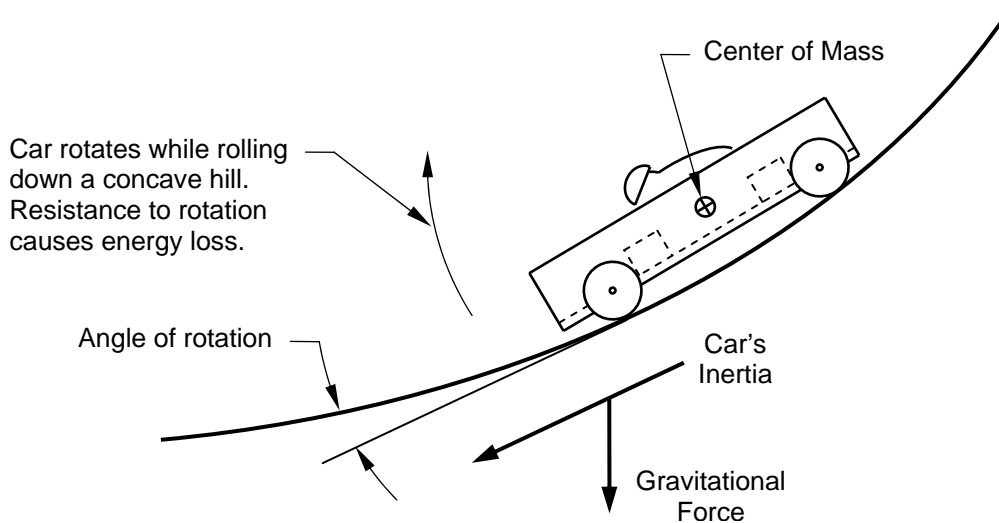

Figure 8

## Basic SBD Information

Stock, Super Stock and Masters Divisions

### Definition of Primary Influence

**(h) Vibration:** A cyclic back and forth motion of an object.

Track surfaces are irregular and cause the car to vibrate up/down, front to back, corner to corner, and side to side.

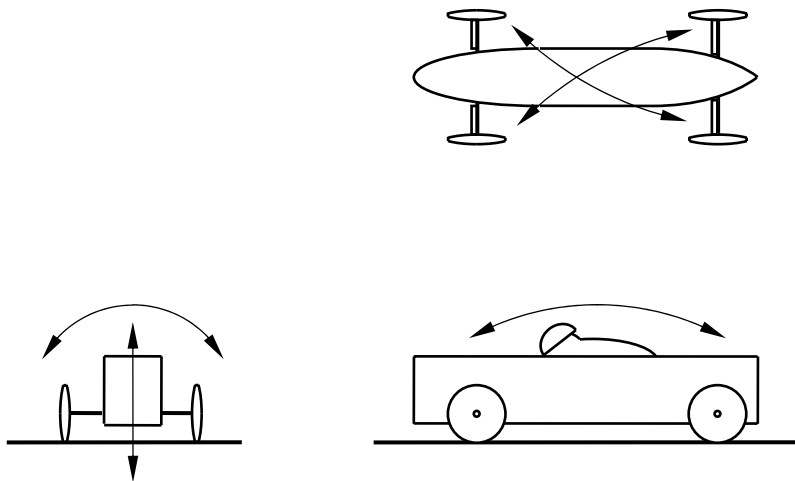

*A car that "rattles" rolling down the hill will be slower than a car that does not rattle – all other things being equal.*

**Figure 9**

# Basic SBD Information

Stock, Super Stock and Masters Divisions

## Definition of Primary Influence

(i) **Friction:** A force that resists the relative motion of two surfaces in contact.

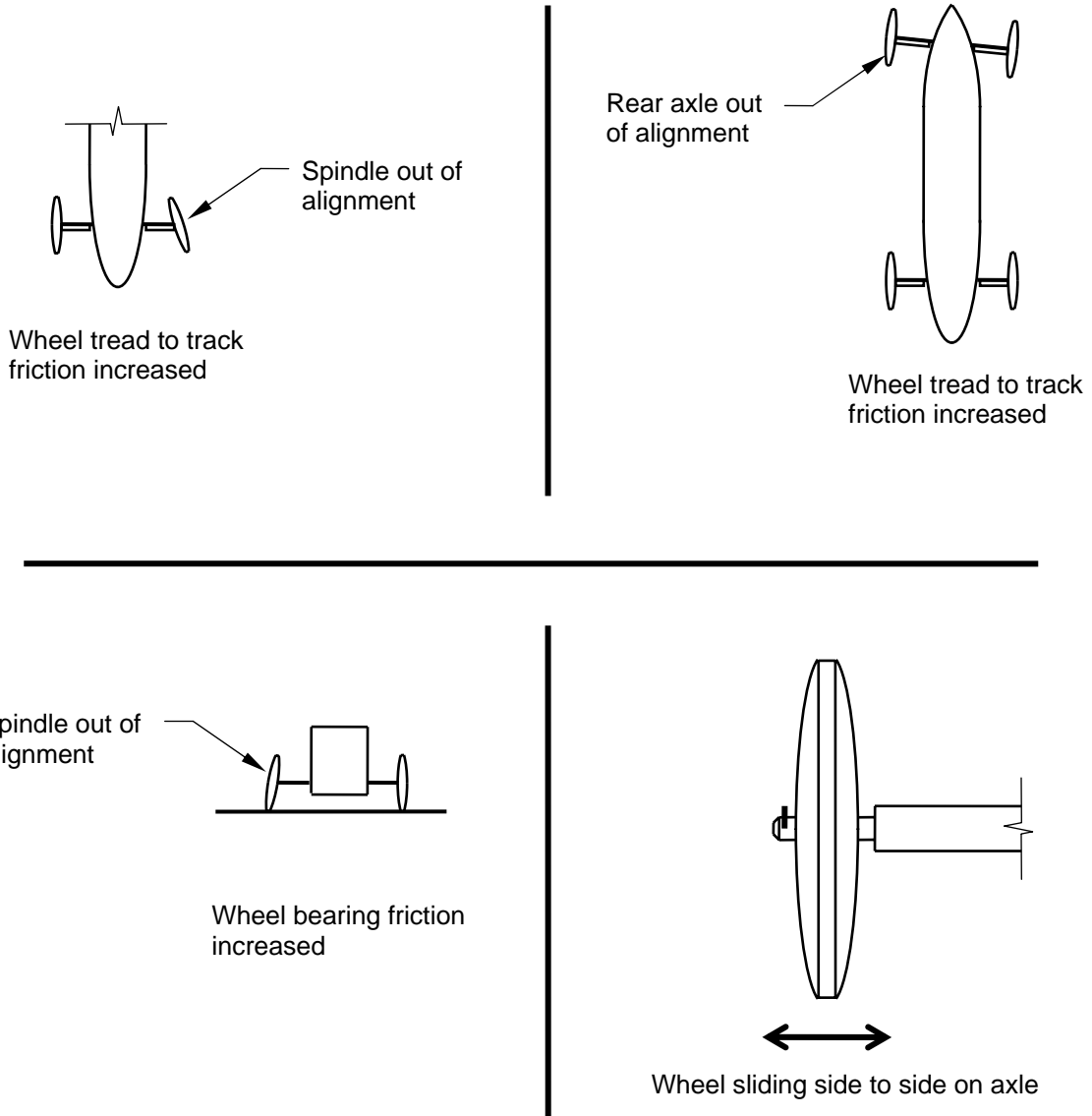

Figure 10

# Basic SBD Information

Stock, Super Stock and Masters Divisions

## Definition of Primary Influence

(j) **Driver:** Individual steering car down hill.

*The driver is the most important component of a car.*

### Example 1

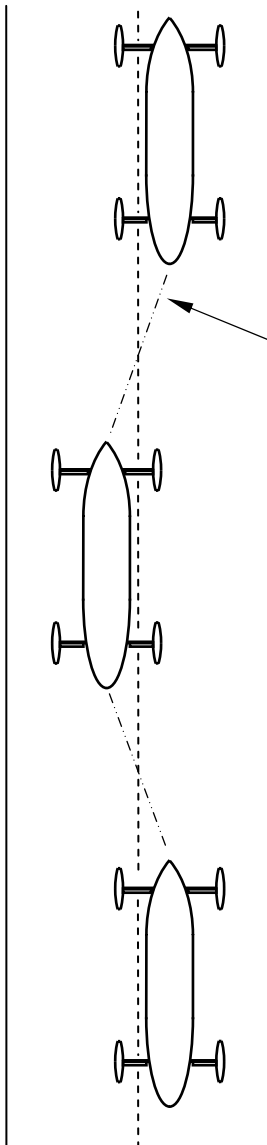

Not driving straight increases length of track and increases wheel friction.

**Example 1:**  
Several large swerves will add approximately six inches to length of track and slows car due to increased wheel friction.

**Example 2:**  
Multiple small swerves significantly slows car due to increased wheel friction and adds about an inch to length of track.

See "Increased Track Length Due to Steering" in *Miscellaneous Info* section.

### Example 2

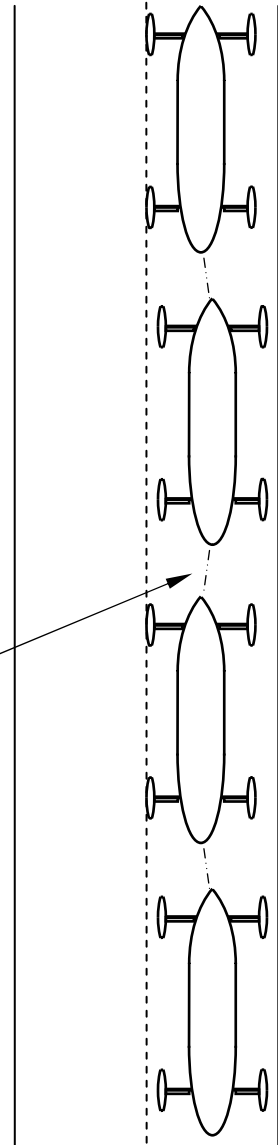

Figure 11

# Basic SBD Information

Stock, Super Stock and Masters Divisions

## Index - Floorboard Conditions

	Page
<b>Floorboard Conditions</b> .....	18
1. Twisted or Wrapped.....	19
2. Cupped.....	19
3. Bowed.....	20
4. Width.....	21
5. Thickness.....	21
6. Rear King Pin Bushing Hole Mislocated Along Center Line.....	22
7. Front King Pin Bushing Hole Mislocated Along Center Line.....	22
8. One King Pin Bushing Hole Mislocated Off Center Line.....	23
9. Both King Pin Bushing Holes Mislocated Off Center Line.....	23
10. King Pin Bushing Hole(s) Not Drilled At 90 Degrees.....	24
11. King Pin Bushing Hole(s) Oversize.....	24
 <b>Ideal Floorboard #1: No Bow or Cup Defects</b> .....	 25
 <b>Ideal Floorboard #2: Bow and Cup Defects Used to Advantage</b> .....	 26
 <b>Floorboard Condition Data Sheet</b> .....	 27

## Basic SBD Information

Stock, Super Stock and Masters Divisions

### Floorboard Conditions

The following pages show the basic physical features of a Soap Box Derby floorboard and conditions that may exist. The intent of these pages is to provide guidance when evaluating a floorboard. Illustrations are provided to help identify conditions and their impact.

Because floorboard material, size dimensions and rules change over the years, dimensional values for the floorboard are not provided.

With all manufactured items (even computer numerical control (CNC) parts), the production process produces similar parts with different dimensions. Most of the parts manufactured will be within the allowed tolerance while some will not. Generally, parts outside of the allowed tolerance present the greater possibility for a speed advantage.

If a floorboard is received from Akron with significant defect(s) (e.g.; split along glue line, badly mislocated holes, twisted, etc.), return it to Akron or request permission to repair it.

It is not suggested or recommended that floorboards be altered or modified to achieve the optimum conditions shown in this document.

Diagram 1 below shows how terms are applied to a floorboard.

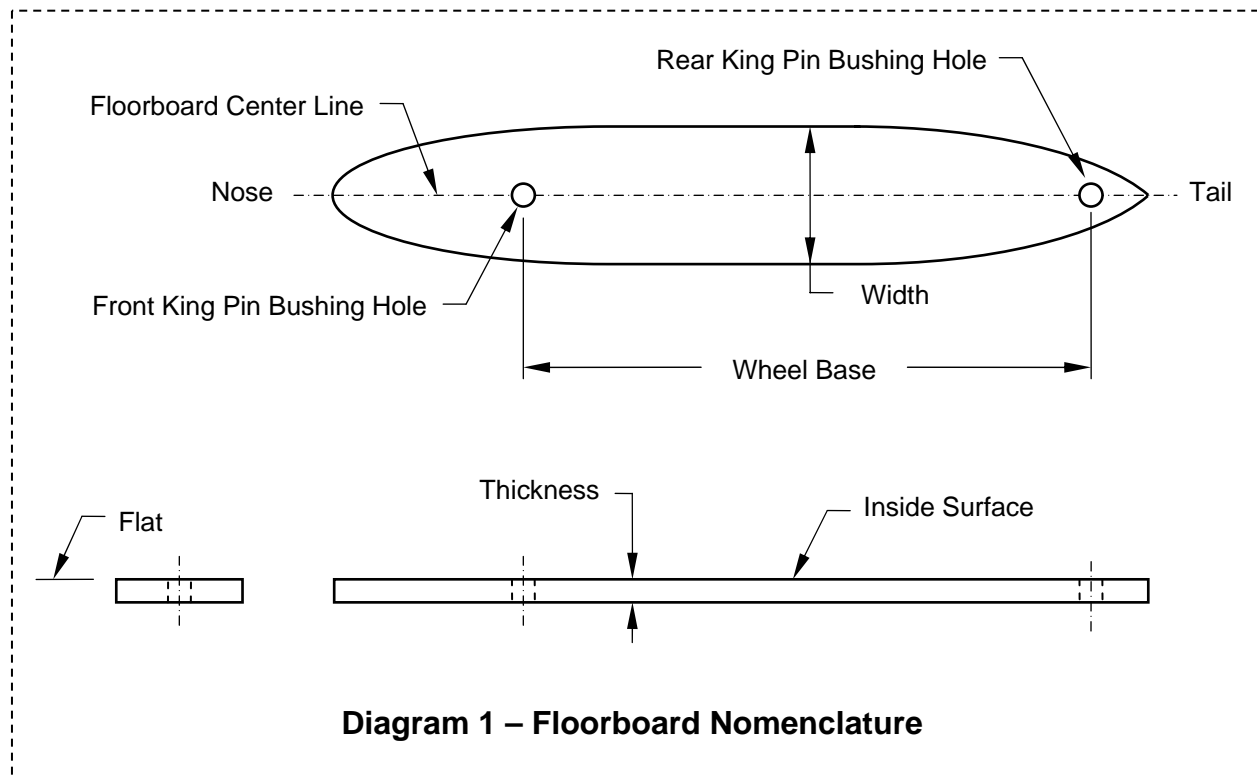

# Basic SBD Information

Stock, Super Stock and Masters Divisions

## 1. Twisted or Wrapped

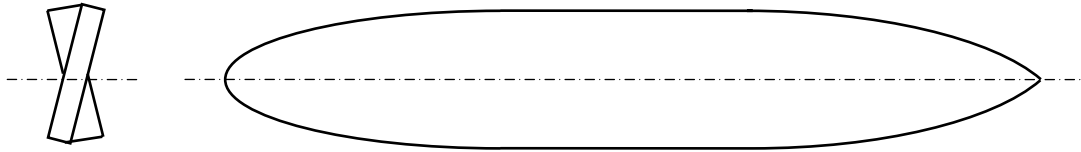

### Impact(s)

- a) Creates cross bind increasing wheel friction.
- b) Difficult to mount car body.
- c) Increases aerodynamic drag.

*Cross bind is unequal weight on wheels from side to side (e.g., more weight on left front than right front wheel).*

---

## 2. Cupped

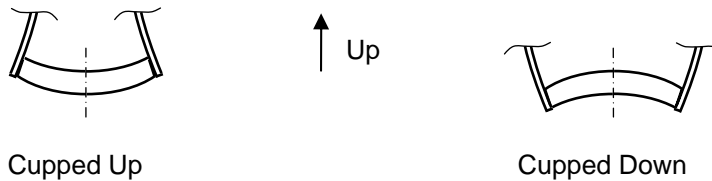

### Impact(s)

#### Cupped Up:

- a) If body shell is raised up, cross section area of car is increased which increases aerodynamic drag
- b) Lowers driver in car decreasing aerodynamic drag.
- c) Lowers Center of Mass increasing Potential Energy.
- d) Improves air flow along bottom decreasing aerodynamic drag.

#### Cupped Down:

- a) Degrades airflow along bottom of car increasing aerodynamic drag.
- b) Raises driver in car increasing aerodynamic drag.
- c) Raises Center of Mass decreasing Potential Energy.

**Figure 12**

## Basic SBD Information

Stock, Super Stock and Masters Divisions

### 3. Bowed

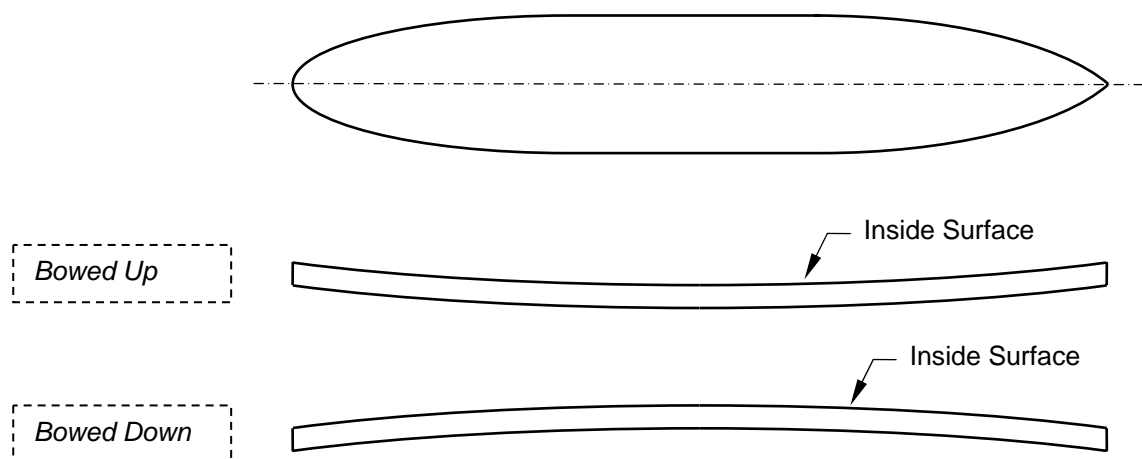

#### Impact(s)

##### Bowed Up:

- Difficult to mount car body.
- If body shell is raised up, cross section area of car is increased which increases aerodynamic drag.
- Lowers driver in car decreasing aerodynamic drag.
- Lowers Center of Mass increasing Potential Energy.
- Tilts king pins which tilts axles/airfoils increasing aerodynamic drag.
- Improves air flow along bottom decreasing aerodynamic drag.

##### Bowed Down:

- Difficult to mount car body.
- If body shell is raised up, cross section area of car is increased which increases aerodynamic drag.
- Raises driver in car increasing aerodynamic drag
- Raises Center of Mass decreasing Potential Energy.
- Degrades airflow along bottom of car increasing aerodynamic drag.
- Tilts king pins which tilts airfoils increasing aerodynamic drag.
- Forcing floorboard flat to mount body may increase stiffness of car.

**Figure 13**

# Basic SBD Information

Stock, Super Stock and Masters Divisions

## 4. Width

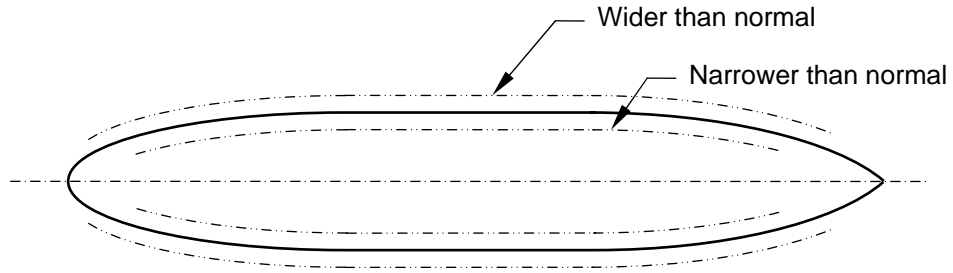

### Impact(s)

Wider: a) Increases cross section area increasing aerodynamic drag.

Narrower: a) Decreases cross section area decreasing aerodynamic drag.

---

## 5. Thickness

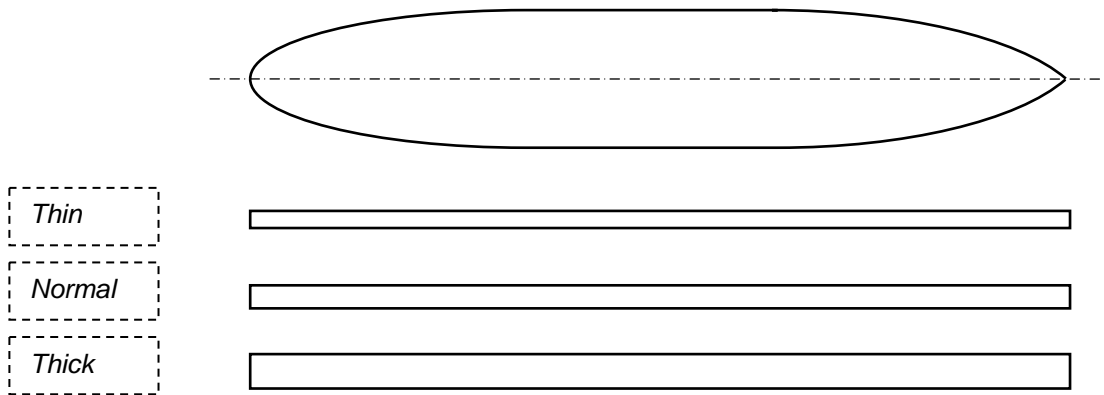

### Impact(s)

Thin:

a) Floorboard flex (bending) may be increased which would increase energy loss (dependent upon driver weight and location of added weight).

Normal:

a) Floorboard cut to basic (standard) thickness.

Thick:

a) Floorboard flex (bending) may be decreased which would decrease energy loss (dependent upon driver weight and location of added weight).

b) Heavier floorboard lowers Center of Mass increasing Potential Energy.

**Figure 14**

## Basic SBD Information

Stock, Super Stock and Masters Divisions

### 6. Rear King Pin Bushing Hole Mislocated Along Center Line

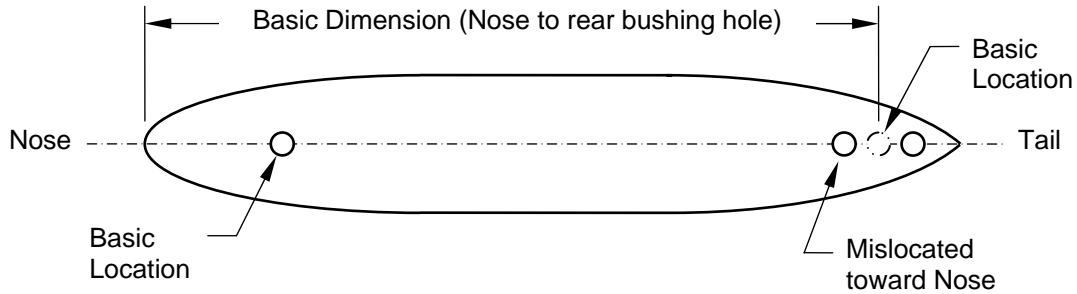

#### Impact(s)

- a) Mislocated toward nose: Center of Mass moved forward (down hill) decreasing Potential Energy.
- b) Mislocated toward tail: Center of Mass moved back (uphill) increasing Potential Energy.

Definition of "Basic": The exact intended location or dimension (distance).

### 7. Front King Pin Bushing Hole Mislocated Along Center Line

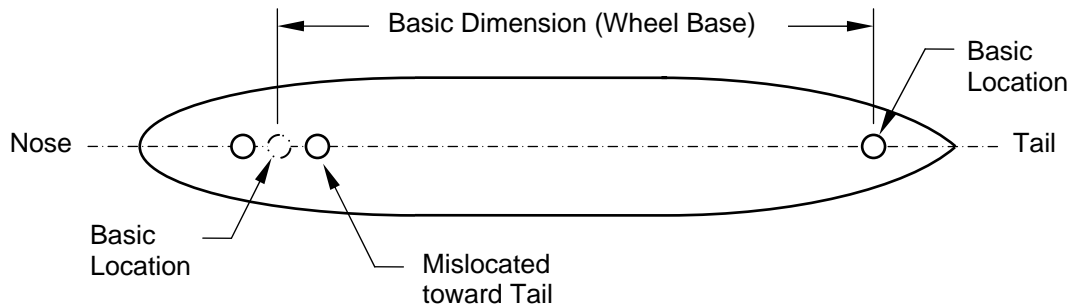

#### Impact(s)

- a) Mislocated toward nose: Center of Mass moved forward (down hill) decreasing Potential Energy.
- b) Mislocated toward nose: Increases acceleration on Drop-Off ramp.
- c) Mislocated toward tail: Center of Mass moved back (uphill) increasing Potential Energy.

Definition of "Basic": The exact intended location or dimension (distance).

Figure 15

## Basic SBD Information

Stock, Super Stock and Masters Divisions

### 8. One King Pin Bushing Hole Mislocated Off Center Line

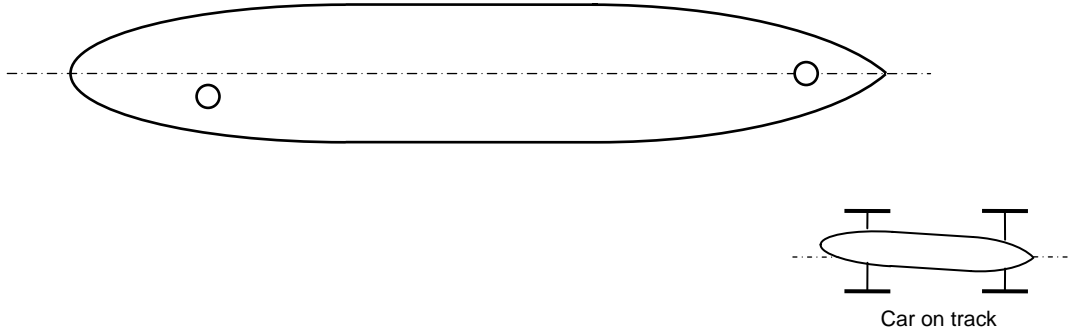

#### Impact(s)

- a) Misaligns car body to air flow increasing aerodynamic drag.
- b) Difficult to drive straight.

---

### 9. Both King Pin Bushing Holes Mislocated Off Center Line

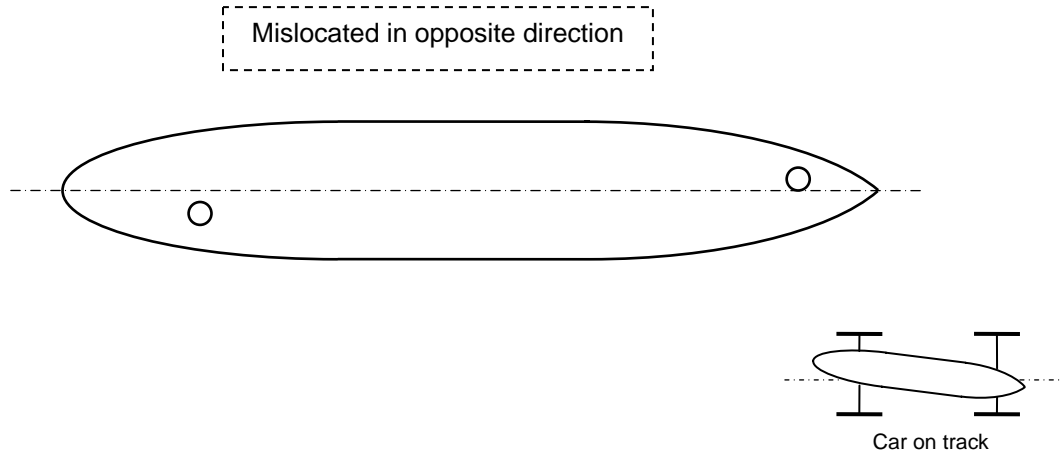

#### Impact(s)

- a) Misaligns car body to air flow increasing aerodynamic drag.
- b) Difficult to drive straight.

**Figure 16**

## Basic SBD Information

Stock, Super Stock and Masters Divisions

### 10. King Pin Bushing Hole(s) Not Drilled At 90 Degrees

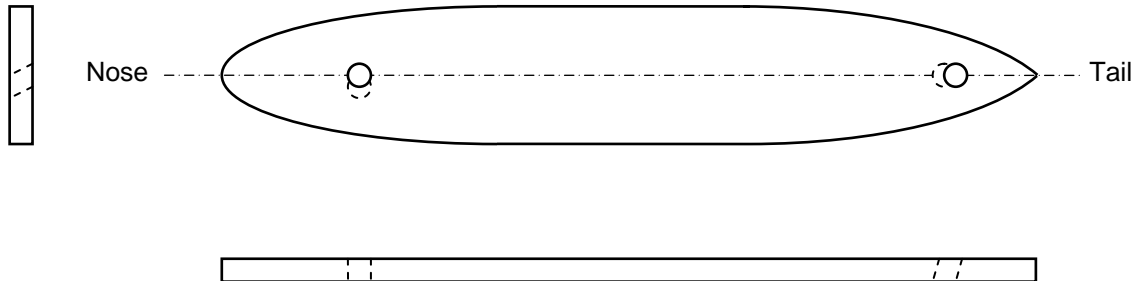

#### Impact(s)

- a) If hole(s) is slanted toward nose or tail, tilts axles/airfoils increasing aerodynamic drag.
- b) If hole(s) is slanted toward side, creates cross bind increasing wheel friction.

---

### 11. King Pin Bushing Hole(s) Oversize

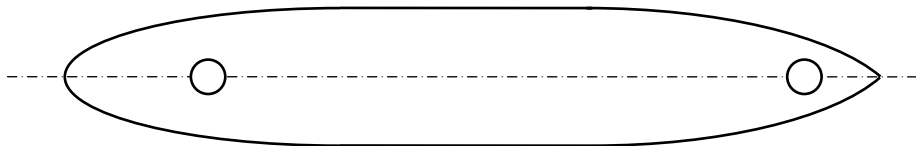

#### Impact(s)

- a) Bushing fit not tight allowing bushing and king pin to move increasing energy loss.

**Figure 17**

# Basic SBD Information

Stock, Super Stock and Masters Divisions

## Ideal Floorboard #1: No Bow or Cup Defects

- 1) Flat
- 2) Narrow
- 3) Thick
- 4) Rear axle bushing hole mislocated toward tail
- 5) Wheel base less than basic
- 6) King pin bushing holes located on floorboard center line
- 7) King pin bushing holes drilled 90 degrees to floorboard inside surface
- 8) King pin bushing holes small diameter

*Note: Bushings should be a tight fit in floorboard and king pin bolts should be a tight fit in bushings.*

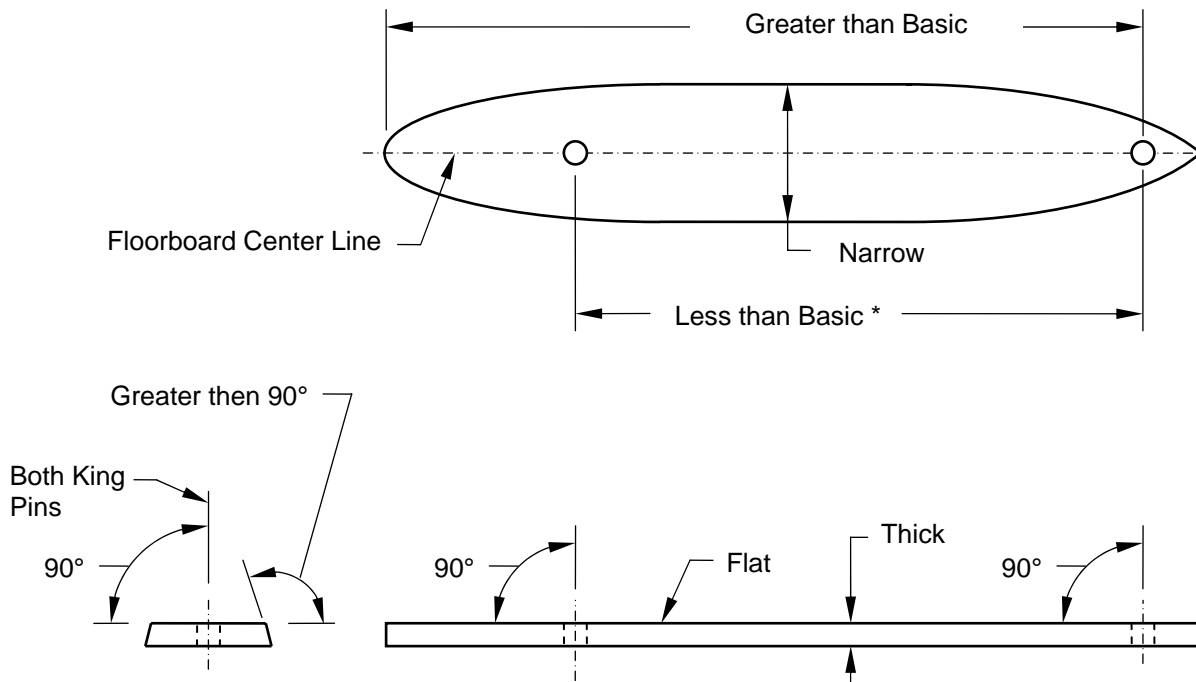

*\* Basic wheel base: Stock – 61"; Super Stock – 63 5/16"; and Masters – 65"*

**Figure 18**

## Basic SBD Information

Stock, Super Stock and Masters Divisions

### Ideal Floorboard #2: Bow and Cup Defects Used to Advantage

- 1) Bowed up
- 2) Cupped up
- 3) Narrow
- 4) Thick
- 5) Rear axle bushing hole mislocated toward tail
- 6) Wheel base less than basic
- 7) King pin bushing holes located on floorboard center line
- 8) King pin bushing holes drilled 90 degrees to ground
- 9) King pin bushing holes small diameter

*Note: Bushings should be a tight fit in floorboard and king pin bolts should be a tight fit in bushings.*

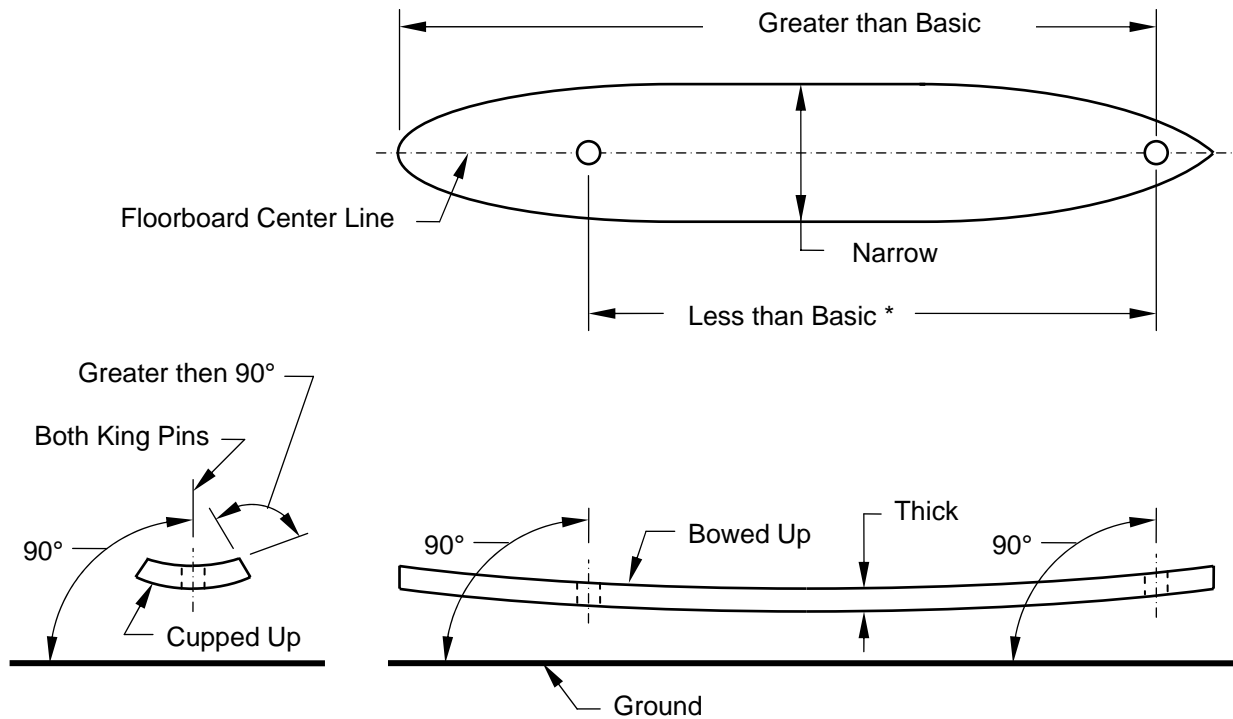

*\* Basic wheel base: Stock – 61"; Super Stock – 63 5/16"; and Masters – 65"*

**Figure 19**

# Basic SBD Information

Stock, Super Stock and Masters Divisions

## Floorboard Condition Data Sheet

Sketch 1 and Sketch 2 may be used to determine and record the condition of a floorboard. The sketches apply to Stock, Super Stock, and Masters Division. All measurements should be taken before king pin bushings have been installed, but may be taken after bushings have been installed.

King Pin Bushings Installed: No \_\_\_\_\_ Yes \_\_\_\_\_

Division: Stock \_\_\_\_\_ Super Stock \_\_\_\_\_ Masters \_\_\_\_\_

Driver: \_\_\_\_\_

### Sequence of measurements:

1. Check for Wrap, Cup and Bow.
2. Take measurements 1 through 3. Record results on Sketch 1.

*continued on next page*

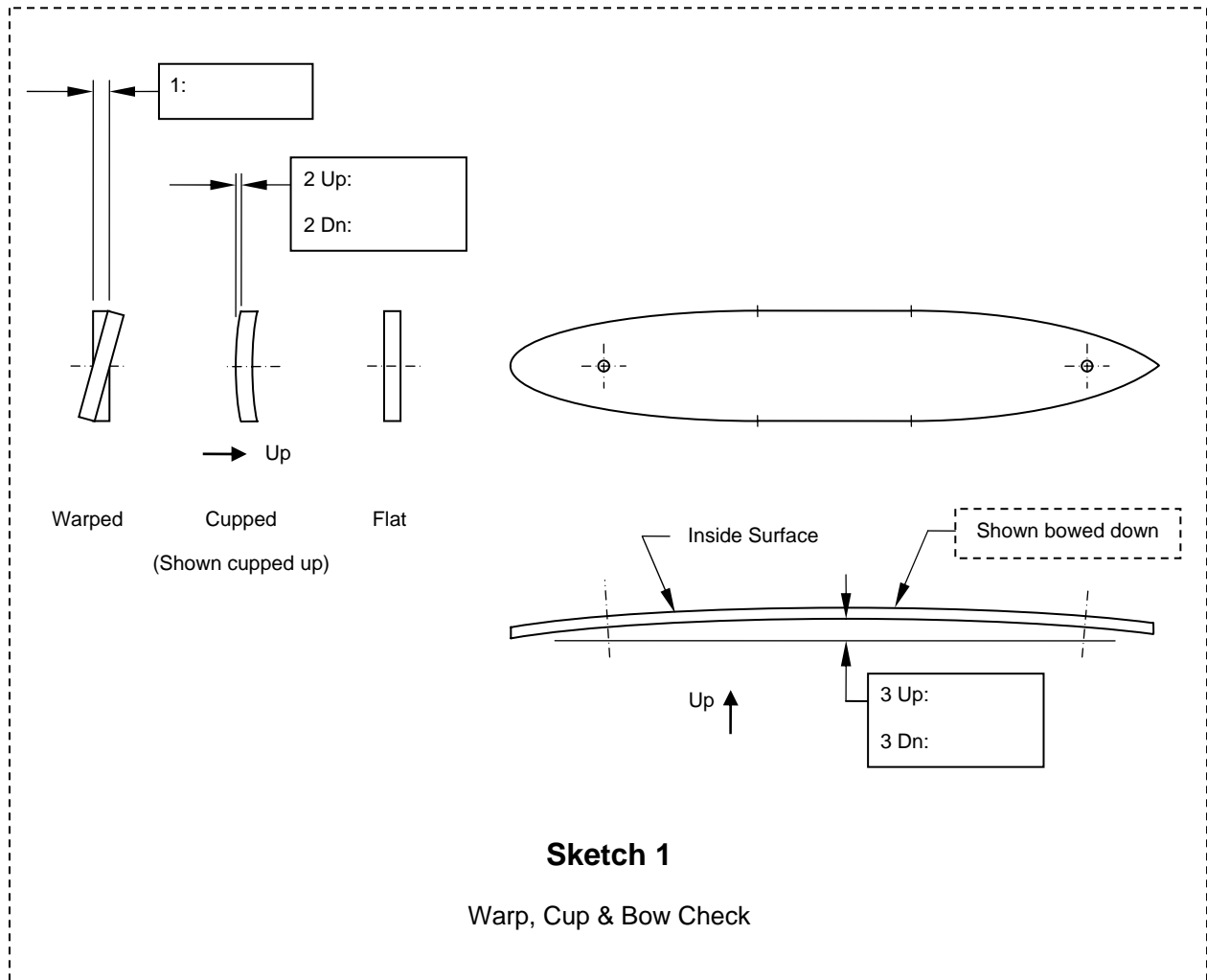

# Basic SBD Information

Stock, Super Stock and Masters Divisions

## Floorboard Condition Data Sheet

Sequence of measurements: *continued*

3. Draw a line on inside surface of floorboard between the front axle bushing hole and rear axle bushing hole. Line must pass through exact center of holes.
4. Extend line to nose of floorboard.
5. Draw a line at 90 degrees to "center" line originating at exact center of each bushing hole.
6. Take measurements 4 through 15. Record results on Sketch 2.

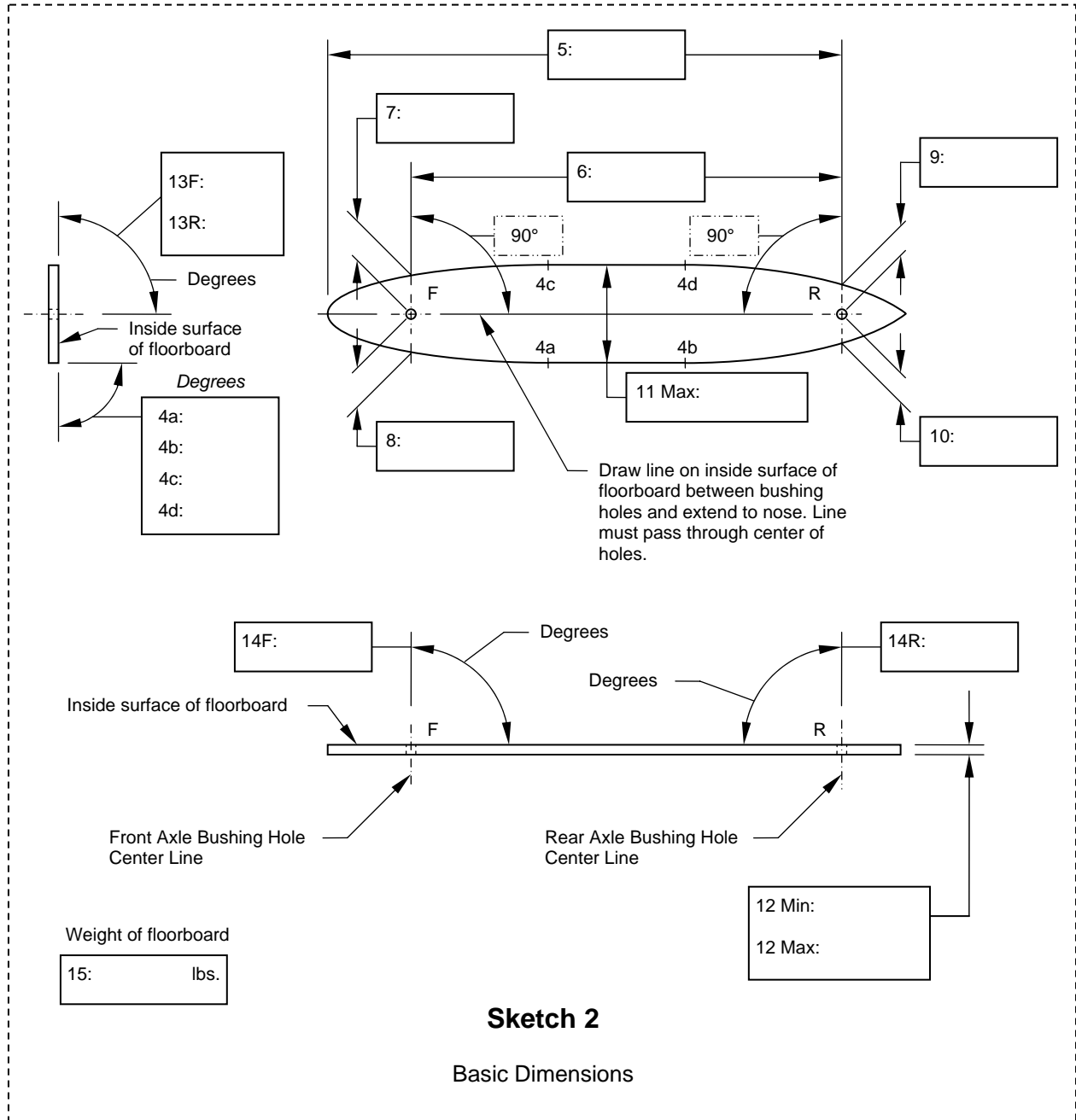

**Basic SBD Information**  
Stock, Super Stock and Masters Divisions

**Index - Axle Conditions**

	Page
<b>Axle Conditions</b> .....	30
1. Square Stock.....	31
a. Twisted.....	31
b. Bowed - Forward and Back.....	31
c. Bowed - Up and Down ( <i>known as Pre-Bow</i> ).....	32
d. Thin.....	32
e. Minimum Distance Between Ends.....	33
f. Corners.....	33
g. Edges.....	33
2. Spindles.....	34
a. Minimum Length.....	34
b. Large Diameter.....	34
c. Constant Diameter.....	35
d. Large Chamfer.....	35
3. King Pin Hole.....	36
a. Centered Between Square Stock Ends.....	36
b. Offset Forward.....	36
c. Small Diameter.....	37
d. Round.....	37
e. Constant Diameter.....	38
f. 90 Degrees.....	38
4. Ideal Axle.....	39

## Basic SBD Information

Stock, Super Stock and Masters Divisions

### Axle Conditions

The following pages show the basic physical features of a Soap Box Derby axle (front and rear) and conditions that may exist. The intent of these pages is to provide guidance when evaluating an axle. Illustrations are provided to help identify conditions and their impact.

Because axle material, size dimensions and rules change over the years, dimensional values for the axle features are not provided.

With all manufactured items (even computer numerical control (CNC) parts), the production process produces similar parts with different dimensions. Most of the parts manufactured will be within the allowed tolerance while some will not. Generally, parts outside of the allowed tolerance present the greater possibility for a speed advantage.

It is not suggested or recommended that axles be altered or modified to achieve the optimum conditions shown in this document.

Diagram 2 below shows how terms are applied to an axle.

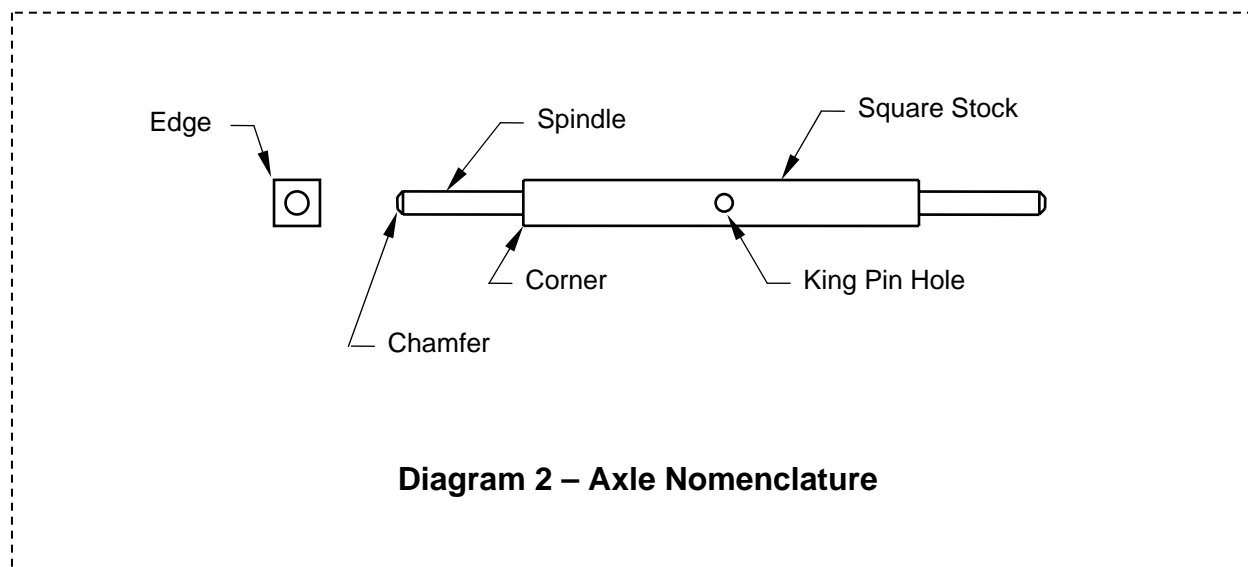

# Basic SBD Information

Stock, Super Stock and Masters Divisions

## 1. Square Stock:

### 1.a. Twisted



#### Impact(s)

- a) Tilts airfoils increasing aerodynamic drag.
- b) May create cross bind increasing wheel friction.

*Cross bind is unequal weight on wheels from side to side (e.g., more weight on left front than right front wheel).*

---

### 1.b. Bowed - Forward and Back

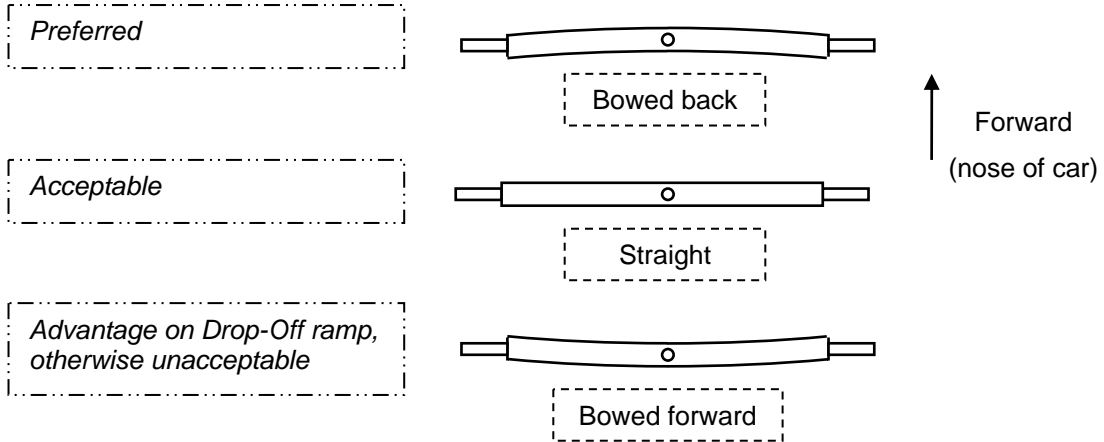

#### Impact(s)

- a) Bowed back moves wheel base toward tail increasing Potential Energy.
- b) Bowed forward moves wheel base toward nose decreasing Potential Energy.
- c) Front axle bowed forward moves wheel base toward nose increasing acceleration on Drop-Off ramp.

**Figure 20**

# Basic SBD Information

Stock, Super Stock and Masters Divisions

## 1. Square Stock: continued

### 1.c. Bowed - Up and Down (known as Pre-Bow)

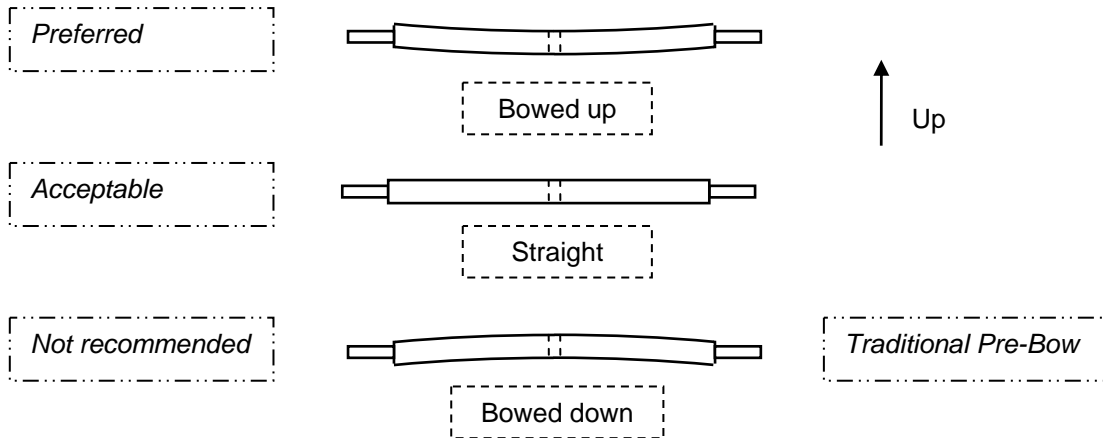

#### Impact(s)

- a) Bowed up lowers Center of Mass increasing Potential Energy.
  - b) Bowed down raises Center of Mass decreasing Potential Energy.
- 

### 1.d. Thin

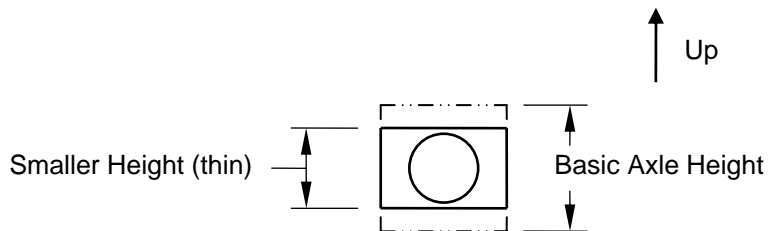

#### Impact(s)

- a) Reduces aerodynamic drag.
- b) Increases axle flexibility.

**Figure 21**

# Basic SBD Information

Stock, Super Stock and Masters Divisions

## 1. Square Stock: continued

### 1.e. Minimum Distance Between Ends

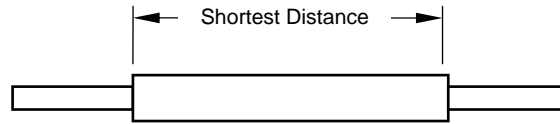

#### Impact(s)

- a) Reduces aerodynamic drag.
- b) Decreases axle flexibility.

### 1.f. Corners

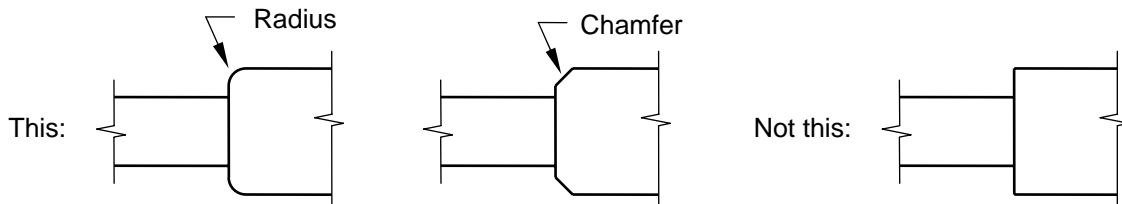

#### Impact(s)

- a) Radius reduces aerodynamic drag.
- b) Chamfer may reduce aerodynamic drag.

### 1.g. Edges



#### Impact(s)

- a) Radius reduces aerodynamic drag.

Figure 22

## Basic SBD Information

Stock, Super Stock and Masters Divisions

### 2. Spindles:

#### 2.a. Minimum Length

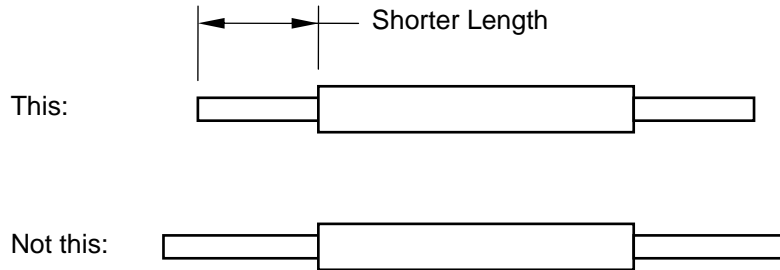

#### Impact(s)

- a) Reduces aerodynamic drag.
- b) Decreases side to side wheel travel on spindle.
- c) With wide wheels and washer, a shorter length may make it difficult to install wheel pin.

*It is important that wheels have a little side to side movement.*

#### 2.b. Large Diameter

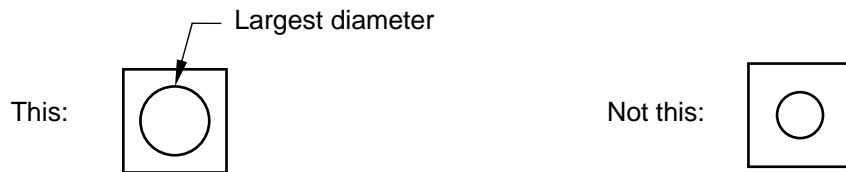

#### Impact(s)

- a) Reduces wheel "wobble" decreasing friction.

Figure 23

## Basic SBD Information

Stock, Super Stock and Masters Divisions

### 2. Spindles: continued

#### 2.c. Constant Diameter

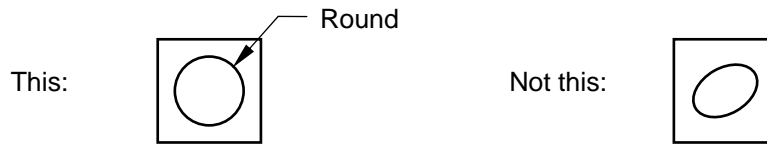

#### Impact(s)

- a) Reduces wheel "wobble" decreasing friction.

#### 2.d. Large Chamfer

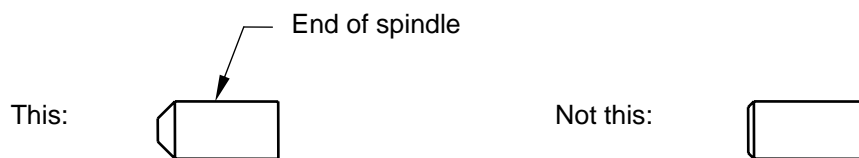

#### Impact(s)

- a) Reduces aerodynamic drag.

Figure 24

## Basic SBD Information

Stock, Super Stock and Masters Divisions

### 3. King Pin Hole:

#### 3.a. Centered Between Square Stock Ends

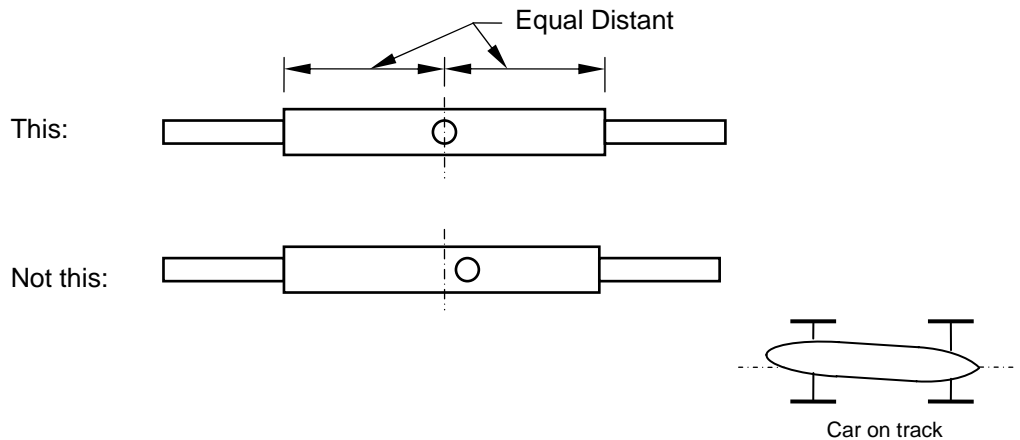

#### Impact(s)

- Off center hole misaligns car body to air flow increasing aerodynamic drag.
- Difficult to drive straight.

#### 3.b. Offset Forward *(mislocated toward nose of car)*

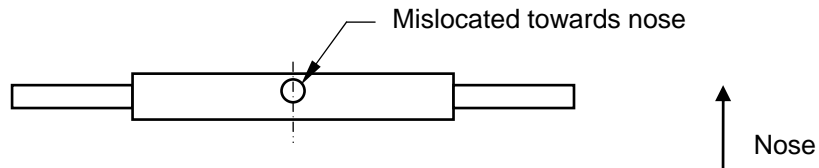

#### Impact(s)

##### Front Axle:

- Mislocated toward nose improves steering control.
- Mislocated toward nose moves Center of Mass up hill increasing Potential Energy.
- Mislocated toward tail reduces steering control.
- Mislocated toward tail moves Center of Mass down hill decreasing Potential Energy.

##### Rear Axle:

- Mislocated toward nose moves Center of Mass up hill increasing Potential Energy.
- Mislocated toward tail moves Center of Mass down hill decreasing Potential Energy.

Figure 25

## Basic SBD Information

Stock, Super Stock and Masters Divisions

### 3. King Pin Hole: continued

#### 3.c. Small Diameter

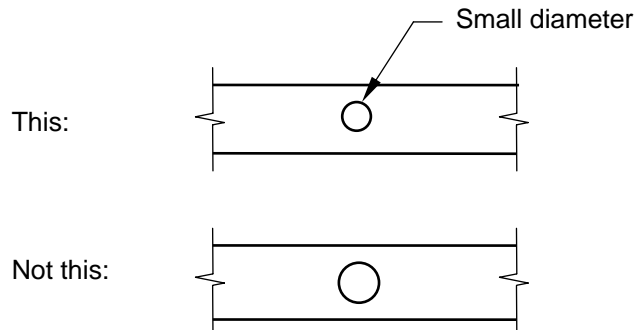

#### Impact(s)

- a) King pin fits tight in a small hole minimizing energy loss.
- b) King pin fits loose in a large hole causing a loss of energy.

---

#### 3.d. Round

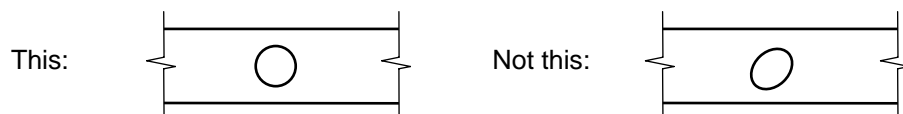

#### Impact(s)

- a) King pin may move in not-round hole causing a loss of energy.

Figure 26

## Basic SBD Information

Stock, Super Stock and Masters Divisions

### 3. King Pin Hole: continued

#### 3.e. Constant Diameter



#### Impact(s)

- a) King pin fits loose in a not-constant diameter hole allowing the axle to “wobble” causing loss of energy.

#### 3.f. 90 Degrees

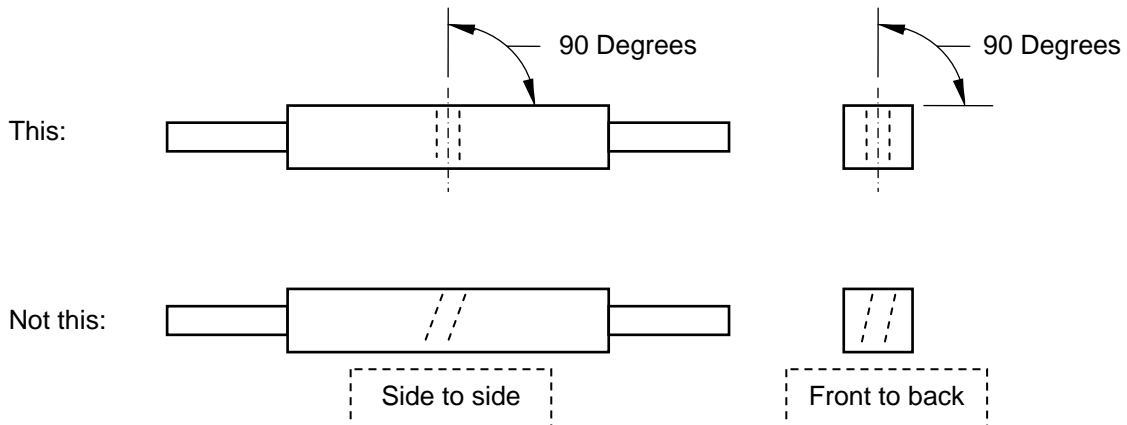

#### Impact(s)

- a) Not 90-degrees side to side:  
- Hole creates cross bind increasing wheel friction.  
- Prevents proper alignment of rear axle increasing aerodynamic drag.
- b) Not 90-degrees hole front to back:  
- Tilts airfoils increasing aerodynamic drag.

Figure 27

## Basic SBD Information

Stock, Super Stock and Masters Divisions

### Ideal Axle – Front and Rear

#### 4. Ideal Axle:

- 1) No twist
- 2) Bowed back
- 3) Bowed up
- 4) Thin
- 5) Shortest length of square stock
- 6) Radius on corners
- 7) Radius on edges
- 8) Shortest length spindles
- 9) Large diameter spindles
- 10) Constant diameter spindles
- 11) Large chamfer on end of spindles
- 12) King pin hole centered between ends of square stock
- 13) King pin hole offset forward
- 14) Small diameter king pin hole
- 15) Round king pin hole
- 16) Constant diameter king pin hole through square stock
- 17) King pin hole drilled 90-degrees to square stock surface

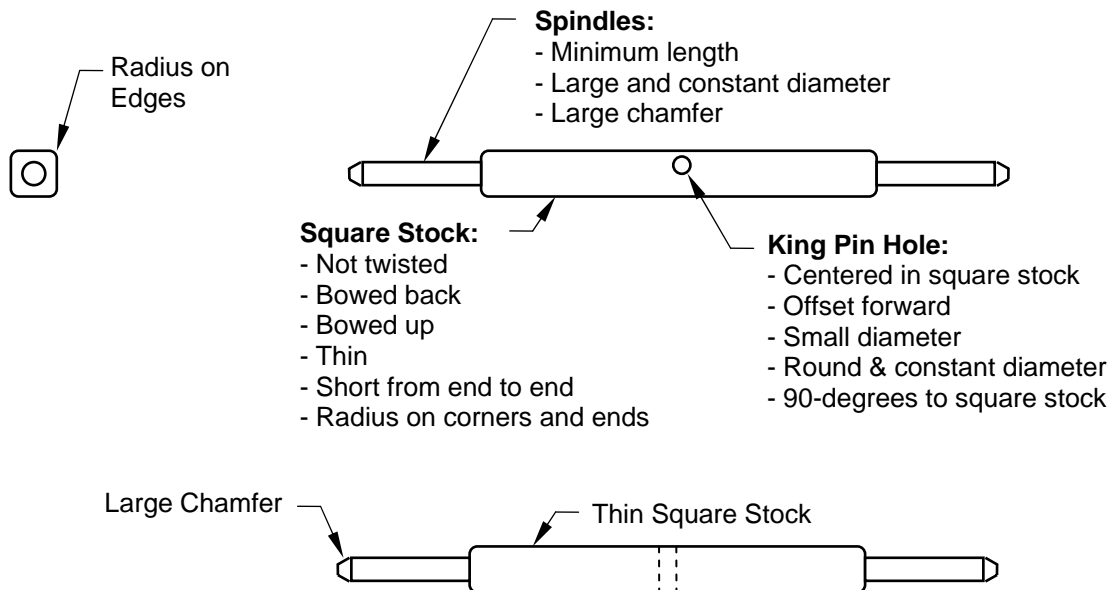

Figure 28

**Basic SBD Information**  
Stock, Super Stock and Masters Divisions

**Index - Weight Distribution**

	Page
<b>Weight Distribution</b> .....	41
1. Track and Ramp Types .....	41
2. General Information .....	42
a. Primary Influences associated with adding weight .....	42
b. Goals .....	42
c. Basics .....	42
d. Generic Recommendations .....	42
e. Exceptions .....	42
3. Potential Energy on Ramp .....	43
4. Potential Energy on Track .....	44
5. Basic Weight Distribution Recommendations .....	45

## Basic SBD Information

Stock, Super Stock and Masters Divisions

### Weight Distribution

The following information is a general guide for determining the location of weight (ballast) added to a SBD car. The two most important considerations when determining where to locate weight being added to a car are slope of the hill and shape of the ramp. See Figure 31, page 45, for basic weight distribution recommendations.

*Note: The best way to determine optimum weight distribution for a specific track and ramp combination is to test on that track/ramp combination.*

#### 1. Track and Ramp Types:

There are three basic hill types used for racing: 1) Constant Slope; 2) Concave Slope; and 3) Convex Slope. See Diagram 3. Tracks built for SBD racing normally have a varying slope (referred to in this document as concave). Streets used for racing are often variations or combinations of the basic hill types and present a greater challenge when trying to determine where to place added weight.

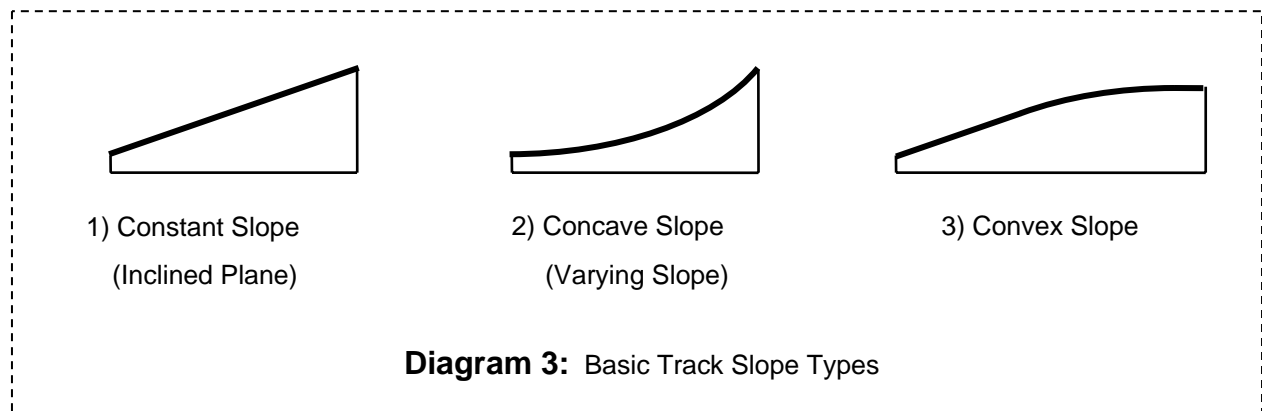

There are three basic ramp types used for racing: 1) Flat Ramp (same slope as track); 2) Standard Ramp (the most common style); and 3) Drop-Off Ramp. See Diagram 4.

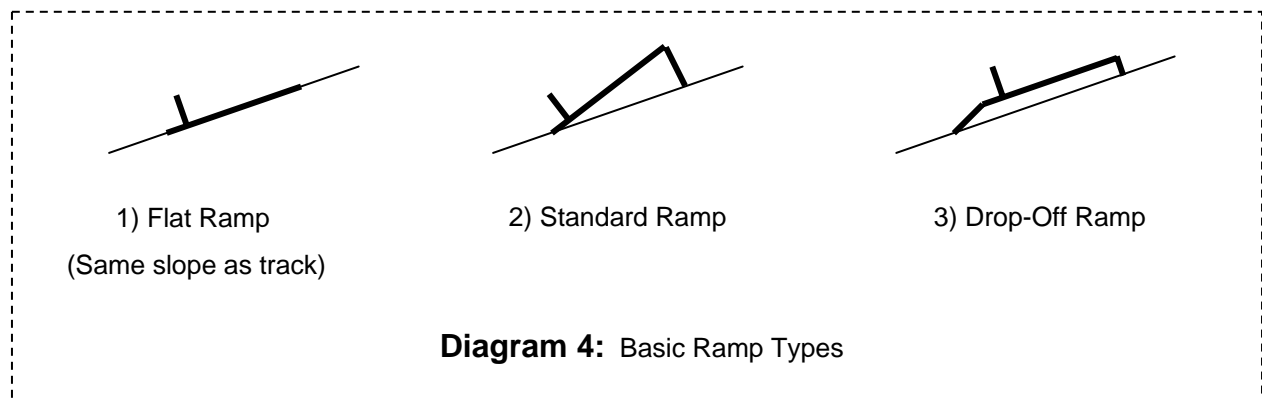

## Basic SBD Information

Stock, Super Stock and Masters Divisions

### 2. General Information – Weight Distribution

#### a. Primary Influences associated with adding weight:

- i. Potential Energy [*Gravitational Potential Energy in the case of SBD cars*]
- ii. Center of Mass [*Also known as Center of Gravity*]
- iii. Balance
- iv. Moment of Inertia

See Figures 1 through 8, pages 6 through 13, for explanation of Primary Influences: Potential Energy, Balance, Center of Mass, Moment of Inertia.

#### b. Goals:

- i. Maximum Potential Energy.
- ii. Lowest possible Center of Mass.
- iii. Appropriate balance for track and ramp combination.
- iv. Minimum Moment of Inertia.

#### c. Basics:

- i. Weight added to a car increases Potential Energy.
- ii. Stacking weight raises the Center of Mass.
- iii. Placement of weight near axles increases car's Moment of Inertia.
- iv. Determining the ideal weight distribution involves trade-offs based upon ramp shape, track slope and track length.

#### d. Generic Recommendations

- i. Car and driver should be at the maximum allowed total weight.
- ii. All weight in car (added and driver) should be as low as possible.
- iii. Ramp type is the first consideration when determining car's balance.
- iv. See Figure 31, page 45, for basic weight distribution recommendations.

#### e. Exceptions

- i. There will be exceptions to all statements and recommendations in this document due to specific and unique track/ramp conditions. Possible exceptions and their impact are not addressed in this document.

## Basic SBD Information

Stock, Super Stock and Masters Divisions

### 3. Potential Energy on Ramp:

- (a) Flat ramp: Location of the Center of Mass is based upon track slope.
- (b) Standard ramp: Locating the Center of Mass toward tail produces a larger vertical drop through ramp to track transition. A larger vertical drop means more Potential Energy. See Example 1 and Example 2 below.
- (c) Drop-Off ramp: Nose heavy is generally better but locating the Center of Mass toward tail may increase Potential Energy depending upon ramp slope, ramp transition to track, track slope, and track length. See Figure 32, page 47.

#### Example 1: Nose heavy car on Standard ramp.

Inches of drop is less through ramp transition with nose heavy car than a tail heavy car.

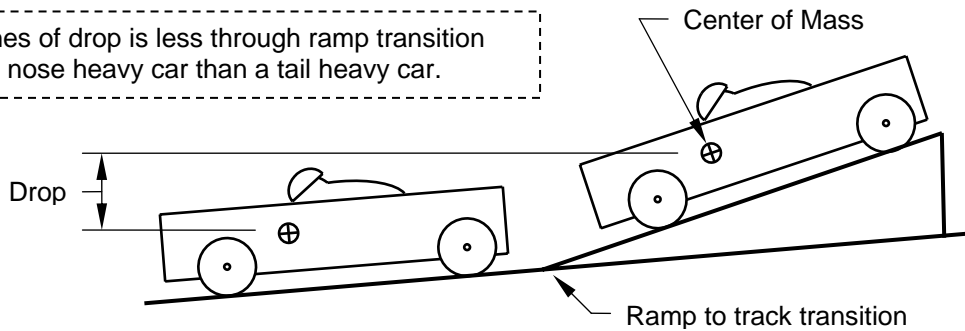

#### Example 2: Tail heavy car on Standard ramp.

Inches of drop is greater through ramp transition with tail heavy car than a nose heavy car or balanced car. This increased drop provides a bigger "push."

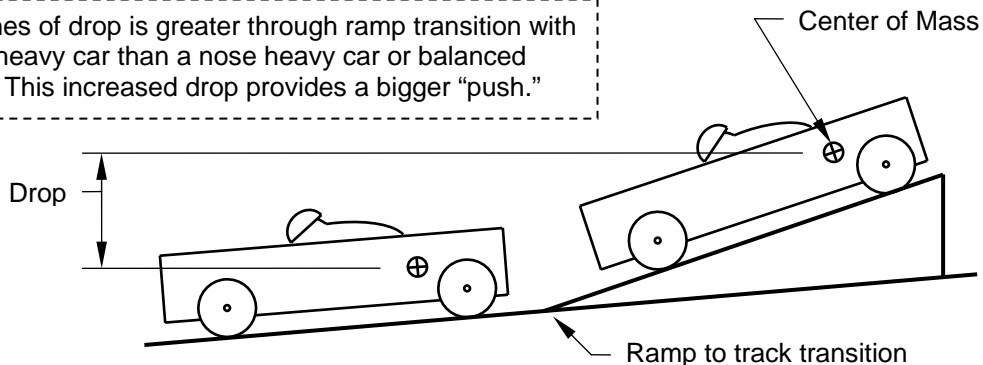

Figure 29

## Basic SBD Information

Stock, Super Stock and Masters Divisions

### 4. Potential Energy on Track:

- (a) Constant (inclined plane) slope: It does not matter if the Center of Mass is high or low. Locating CM toward tail will increase Potential Energy but also increases rear wheels friction.
- (b) Concave (varying) slope: A low Center of Mass produces greater vertical drop of weight from top of hill to bottom than a high Center of Mass. A larger vertical drop means more Potential Energy. See illustration below.
- (c) Convex slope: A high Center of Mass produces greater vertical drop of weight increasing Potential Energy.

*A tail heavy car (CM toward tail) will have increased Potential Energy but, increased rear wheels friction may decrease speed more than additional PE will increase speed.*

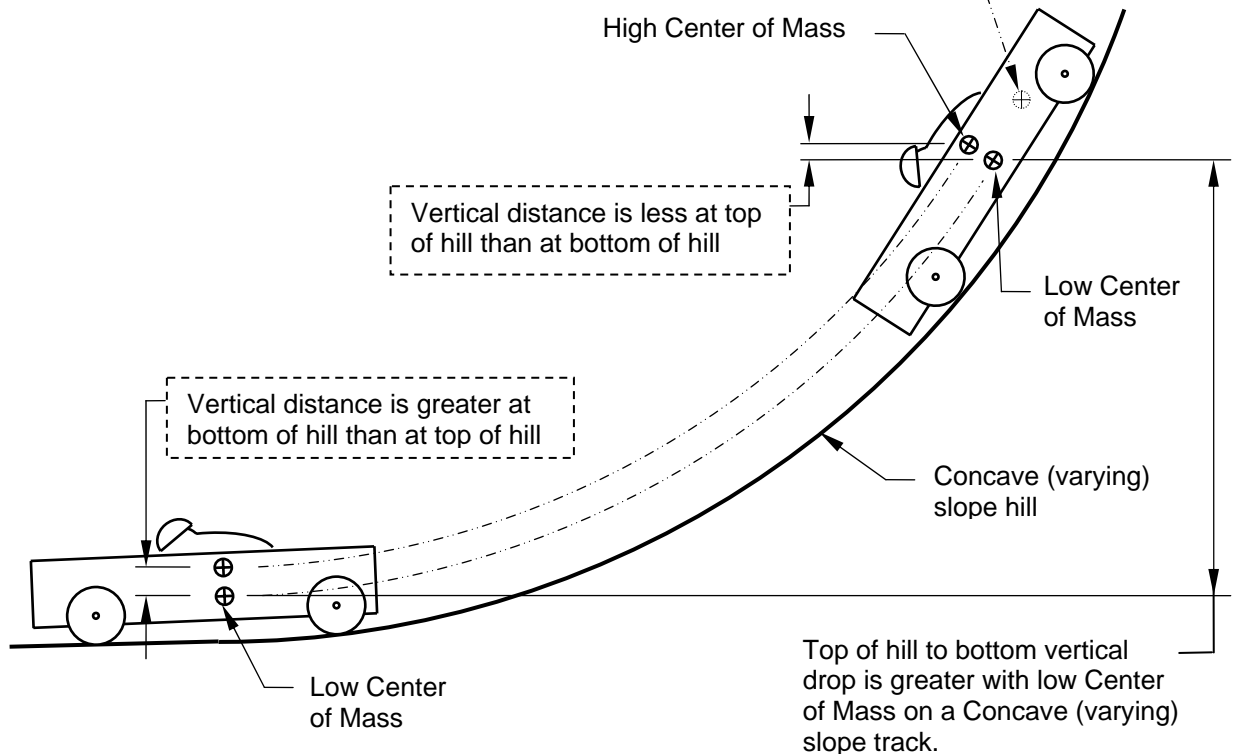

Figure 30

# Basic SBD Information

Stock, Super Stock and Masters Divisions

## 5. Basic Weight Distribution Recommendations

### 1. Constant Slope Track

(a) Flat ramp:

Weight centered - balanced

(b) Standard ramp:

Maximum weight on rear axle

(c) Drop-Off ramp:

Weight at axles - nose heavy

See Note 2 on page 46.

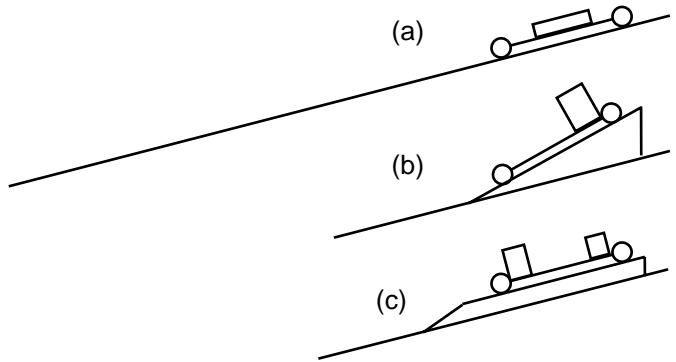

### 2. Concave Slope Track

(a) Flat ramp:

Weight centered - balanced

(b) Standard ramp:

Maximum weight on rear axle

(c) Drop-Off ramp:

Weight at axles - nose heavy

See Note 3 on page 46.

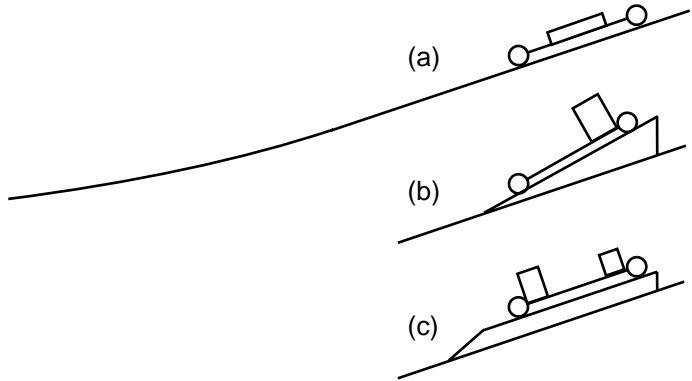

### 3. Convex Slope Track [See Figure 32, page 47]

(a) Flat ramp:

Maximum weight on front axle

(b) Standard ramp:

Maximum weight on rear axle

(c) Drop-Off ramp:

Maximum weight on front axle

See Note 4 on page 46.

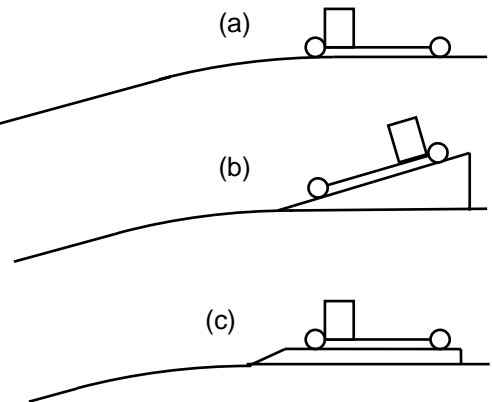

Figure 31

## Basic SBD Information

Stock, Super Stock and Masters Divisions

### Notes - Figure 31:

1. Only testing on a specific track and ramp combination will determine the best weight distribution for that track and ramp.
2. **Constant Slope Track**
  - (a) Flat Ramp: Racing tail heavy (see Figure 6, page 11) will increase Potential Energy and may be an advantage but, increasing weight on rear wheels increases wheel friction. Increased rear wheels friction may slow the car's speed more than the speed gained by having more Potential Energy (especially if wheels are slow or "bad"). Wheels used at rallies and Akron range from good to very bad.
  - (b) Standard Ramp: Racing tail heavy is such a significant advantage, due to the ramp to track transition, that it overrides other considerations.
  - (c) Drop-Off Ramp: A longer wheel base is the most effective method of increasing speed. Racing nose heavy may increase speed depending upon ramp shape, track slope and track length.
3. **Concave Slope Track**
  - (a) Flat Ramp: Racing with low weight will produce the maximum advantage.
  - (b) Standard Ramp: Racing tail heavy is such a significant advantage, due to the ramp to track transition, that it overrides other considerations.
  - (c) Drop-Off Ramp: A longer wheel base is the most effective method of increasing speed. Racing nose heavy may increase speed depending upon ramp shape, track slope and track length.
4. **Convex Slope Track**
  - (a) Flat Ramp: A longer wheel base is the most effective method of increasing speed. Racing nose heavy may increase speed depending upon track slope and length.
  - (b) Standard Ramp: Racing tail heavy is such a significant advantage, due to the ramp to track transition, that it overrides other considerations.
  - (c) Drop-Off Ramp: A longer wheel base is the most effective method of increasing speed. Racing nose heavy may increase speed depending upon ramp shape, track slope and track length.

# Basic SBD Information

Stock, Super Stock and Masters Divisions

## Example of how weight will shift as conditions change on a Convex hill and Drop-Off ramp

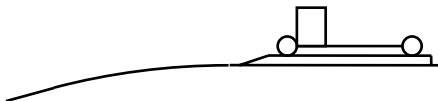
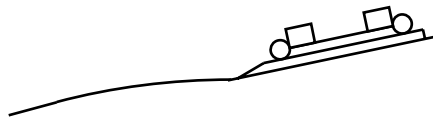
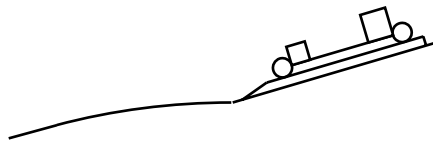
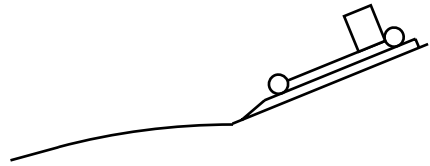

As ramp slope increases the weight distribution should be moved toward the tail of car creating more Potential Energy

Ramp slope almost level

Figure 32

## Basic SBD Information

Stock, Super Stock and Masters Divisions

### Index – Miscellaneous Information

	Page
<b>Miscellaneous Information</b>	
1. Time into Inches Conversion Data.....	50
2. Increased Track Length Due to Steering.....	51
3. Balanced Verse Ramp Angle (future addition)	---

## **Basic SBD Information**

Stock, Super Stock and Masters Divisions

## **Miscellaneous Information**

The following miscellaneous information is provided to help the contestant better understand car setup and racing.

# Basic SBD Information

Stock, Super Stock and Masters Divisions

## 1. Time into Inches Conversion Data

**Basic Data:** 1 hour = 60 minutes = 3,600 seconds  
 1 mile = 5,280 feet = 63,360 inches

1 MPH = 1 mile in 1 hour  
 1 MPH = 5,280 ft in 60 minutes  
 1 MPH = 63,360 inches in 3,600 seconds  
 1 MPH = 17.6 inches in 1.0 seconds

**Car Lengths:** 75 inches (6 ft 3 in) - Stock  
 75 inches (6 ft 3 in) - Super Stock  
 84 inches (7 ft) - Masters

### Inches per second Chart:

MPH	Inches per			
	1.00 Second	.10 Sec.	.01 Sec.	.001 Sec.
10	176.0 (14 ft 8 in)	17.60	1.76	.18
15	264.0 (22 ft 0 in)	26.40	2.64	.26
20	352.0 (29 ft 4 in)	35.20	3.52	.35
25	440.0 (36 ft 8 in)	44.00	4.40	.44
26	457.6 (38 ft 2 in)	45.76	4.57	.46
27	475.2 (39 ft 7 in)	47.52	4.75	.48
28	492.8 (41 ft 1 in)	49.28	4.92	.49
29	510.4 (42 ft 6 in)	51.04	5.10	.51
30	528.0 (44 ft 0 in)	52.80	5.28	.53
31	545.6 (45 ft 6 in)	54.46	5.44	.54
32	563.2 (46 ft 11 in)	56.32	5.63	.56
33	580.8 (48 ft 5 in)	58.08	5.80	.58
34	598.4 (49 ft 10 in)	59.84	5.98	.60
35	616.0 (51 ft 4 in)	61.60	6.16	.62

### Equivalents

1/64"	.016"	.40 MM
1/32	.031	.79 MM
1/16	.063	1.59 MM
3/32	.094	2.38 MM
1/8	.125	3.18 MM
5/32	.156	3.97 MM
3/16	.188	4.76 MM
7/32	.219	5.56 MM
1/4	.250	6.35 MM
9/32	.281	7.14 MM
5/16	.313	7.94 MM
11/32	.344	8.73 MM
3/8	.375	9.53 MM
13/32	.406	10.32 MM
7/16	.438	11.11 MM
15/32	.469	11.91 MM
1/2"	.500	12.70 MM
17/32	.531	13.49 MM
9/16	.563	14.29 MM
19/32	.594	15.08 MM
5/8	.625	15.88 MM
21/32	.656	16.67 MM
11/16	.688	17.46 MM
23/32	.719	18.26 MM
3/4	.750	19.05 MM
25/32	.781	19.84 MM
13/16	.813	20.64 MM
27/32	.844	21.43 MM
7/8	.875	22.23 MM
29/32	.906	23.02 MM
15/16	.938	23.81 MM
31/32	.969	24.61 MM
1"	1.00"	25.40 MM

**Single Phase example.** Winning time of .064 seconds at finish line speed of 28 MPH:

Phase time multiplied by inches per second for 28 MPH equals win in inches.

$$.064 \times 492.8 \text{ inches} = 31.54 \text{ inches}$$

**Heat (two phase) example.** Overall time (both phases) of 1.44 seconds at 28 MPH:

Phase time multiplied by inches per second for MPH at finish line equals win in inches.

$$1.44 \text{ divided by } 2 = .72 \times 492.8 \text{ inches} = 354.8 \text{ inches (29 feet 6 inches)}$$

### Approximation for most tracks:

.001 seconds = 1/2 inch

.010 seconds = 5 inches

.100 seconds = 49 inches (4 feet 1 inch)

1.00 seconds = 41 feet

# Basic SBD Information

Stock, Super Stock and Masters Divisions

## 2. Increased Track Length Due to Steering

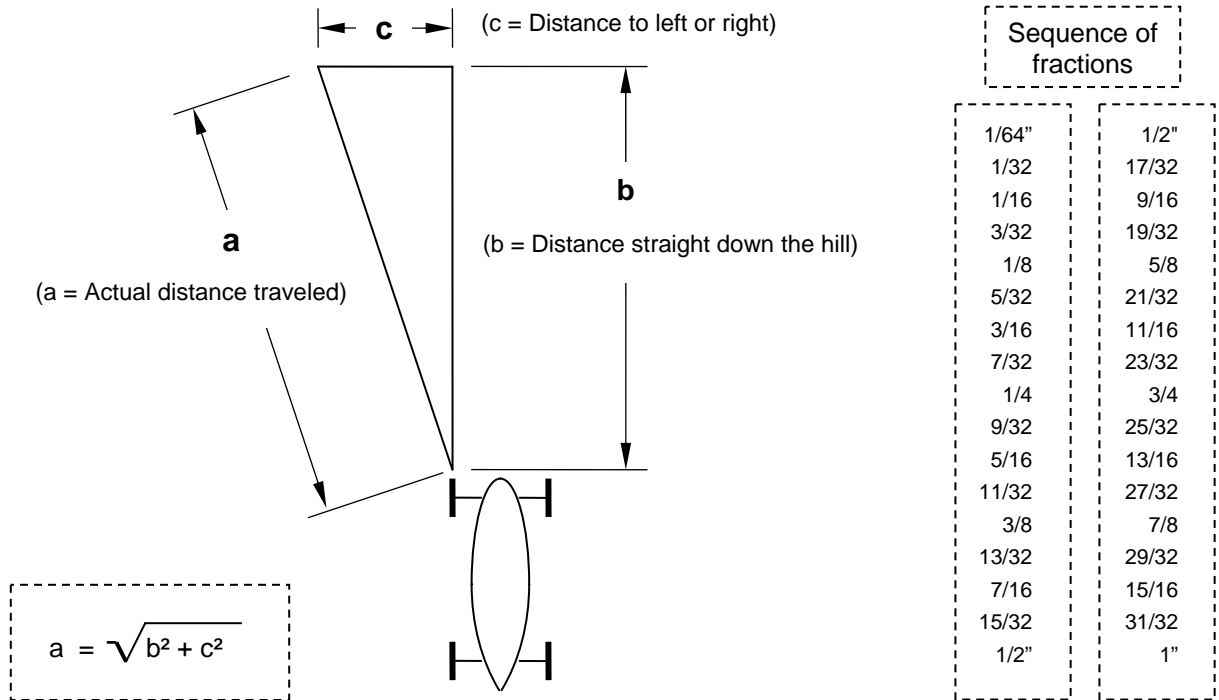

		<b>a</b> Increased distance traveled (fractions rounded up)					
<b>b</b> \ <b>c</b>	20' (feet)	30'	40'	50'	100'	150'	200'
	240" (inches)	360"	480"	600"	1,200"	1,800"	2,400"
6" (inches)	3/32"	1/16"	1/32"	1/32"	1/64"	---	---
9"	3/16"	1/8"	3/32"	1/16"	1/32"	1/32"	1/64"
12" (1 foot)	5/16"	3/16"	5/32"	1/8"	1/16"	1/32"	1/32"
24" (2 feet)	1 3/16"	13/16"	19/32"	1/2"	1/4"	5/32"	1/8"
36" (3 feet)	2 11/16"	1 13/16"	1 11/32"	1 3/32"	17/32"	3/8"	9/32"
48" (4 feet)	4 3/4"	3 3/16"	2 13/32"	1 29/32"	31/32"	21/32"	1/2"
60" (5 feet)	7 3/8"	4 31/32"	3 3/4"	3"	1 1/2"	1"	3/4"
120" (10 ft)	28 11/32"	19 15/32"	14 25/32"	11 7/8"	6"	4"	3"
180" (15 ft)	60"	42 1/2"	32 21/32"	26 7/16"	13 7/16"	9"	6 3/4"

# Basic SBD Information

Stock, Super Stock and Masters Divisions

## 2. Increased Track Length Due to Steering: continued

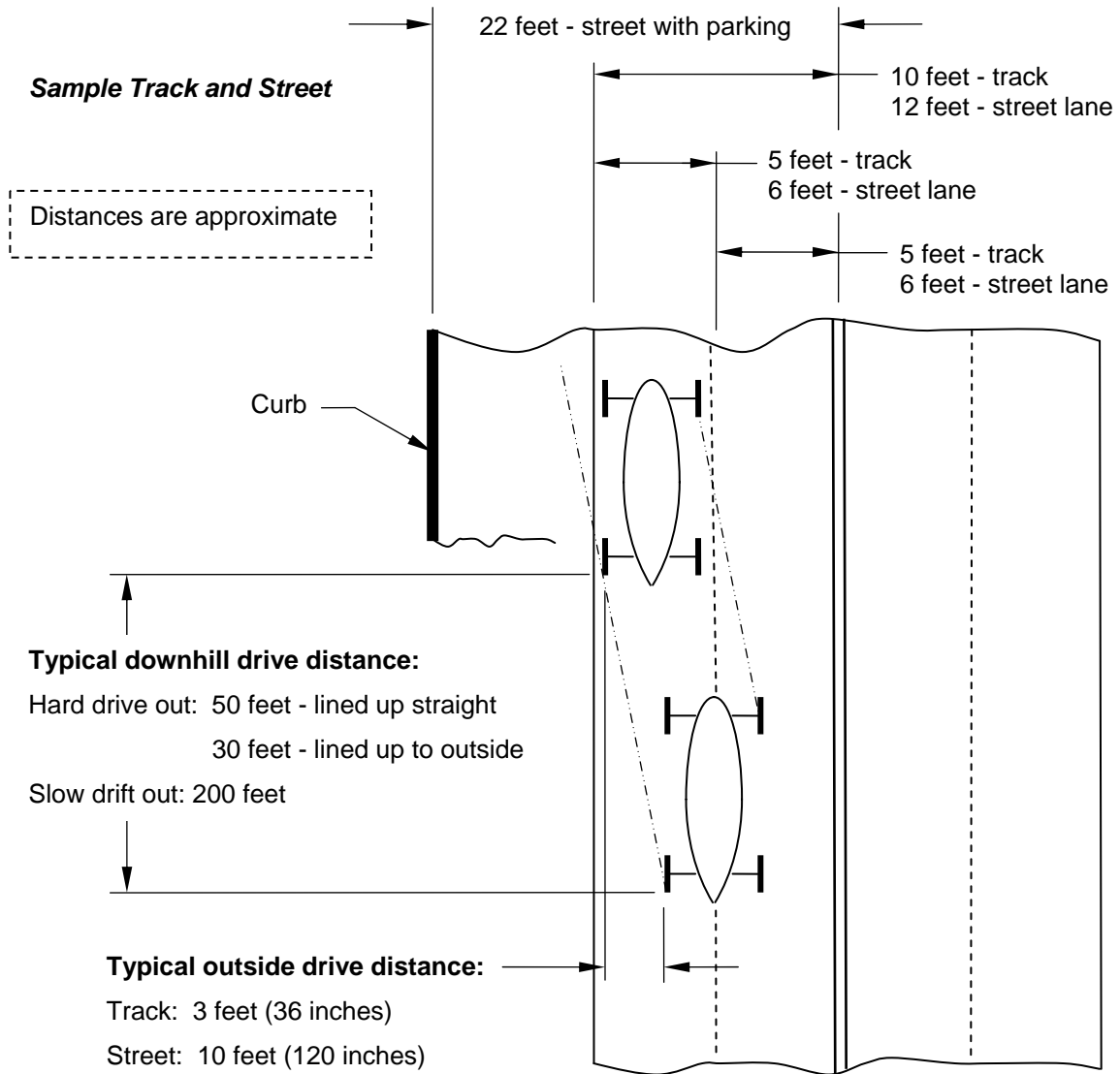

### Wheel to wheel dimension

